



Cell 2000 Manual



Revision 5.0

Before You Get Started

IMPORTANT:

This manual contains important instructions that should be followed during installation, operation and maintenance of the Cell 2000 controller. Carefully read and follow all safety instructions in this manual. Make sure that safety labels are always in good condition and replace missing or damaged safety labels.



Before performing any service or maintenance inside the controller or when connecting or disconnecting any wires, **DISCONNECT the power** and **WAIT 90 seconds** to allow the capacitor bank inside the controller to discharge to a level below 50V.

DO NOT turn on the power to the controller before terminating all wiring connections and closing the cover door.

DO NOT connect power wiring to the controller before mounting the box.

DO NOT service the device if your hands are wet or damp. Always make sure hands are dry before working on the controller.

DO NOT modify equipment inside the controller.

DO NOT remove any parts of the controller unless instructed by this manual.

The controller should be **installed and inspected by technically qualified personnel**, and if the controller is not installed in compliance with national and local electrical codes and ENFusion™ recommendations, the controller can be damaged and fail to operate.

FOLLOW instructions in this manual and labels inside the controller for proper and successful installation.

TABLE OF CONTENTS

INSTALLATION 1

Task 1: Mount the Cell 2000..... 2

Step One: Decide Best Location..... 2

 Important Pre-Installation Warnings..... 2

 Cell 2000 Requirements for Safe Installation..... 2

 Cell 2000 Mounting Clearances..... 3

 Cell 2000 Dimensions..... 4

Step Two: Mount the Cell 2000 4

 Cell 2000 Unit Mounting Instructions 4

Task 2: Wire the Cell 2000 7

Step One: Review Wiring Requirements and Warnings 7

 Installation Requirements 7

 Wiring Warnings..... 7

Step Two: Review System Wiring Diagrams..... 7

 Review Overview Diagram of Cell 2000 Showing Three Wire Glands 7

 Review Cell 2000 System Wiring Diagram 9

 Wiring For Single-Phase Motor Loads 10

Step Three: Wire to DC (Solar) Sources..... 10

 Wire to DC Sources as Per Wiring Diagram 10

 Tighten the Power Conductors..... 11

Step Four: Set Cell 2000 DIP Switch Settings 12

 Set DIP Switches 1, 2, or 3 to Match Your Motor..... 13

 Set DIP Switches 4 and 5 for Overcurrent Protection 14

 Set DIP Switch 6 (If DIP Switch 2 Is Set for Single -Phase Operation).... 15

 Install Cover Door and Tighten It 15

Step Five: (Optional) Set Cell 2000 Sensor Settings 15

 Remote Turn On/Off With Digital Input or Standard Float Switch..... 15

Task 3: Complete Installation Notes 17

 After Installation, Complete Installation Notes..... 17

 Tech Support Hotline: 877 230 7501..... 18

 Keep This Manual With Your Cell 2000 Unit..... 18

CONFIGURATION 19

Task 4: Configure the Cell 2000 20

Step One: Size the Solar Panel Array to Motor Load Power Requirements .. 20

OPERATION..... 21

Task 5: Initial Cell 2000 Startup 22

Step One: Start Cell 2000 for the First Time..... 22

Step Two: Understand Meaning of Cell 2000’s LED Lights 23

 Motor Is Properly Connected 23

 Cell 2000 Overload Protection 23

Step Three: Manually Shut Down Cell 2000 Operation..... 24

 Understanding Automatic Shutdown of Cell 2000 24

 Automatic Shutdown With Tank or Well Float Switch..... 24

 Automatic Shutoff Due to Temperature 24

 Power Deration Mode 24

MAINTENANCE OF CELL 2000 25

Task 6: Perform Recommended Maintenance 26

 Inspect Every Three Months 26

 Maintain Optimal Operational Conditions 26

 Keep Clear of External Obstructions 26

 Don’t Operate in Freezing Conditions 26

 Check External Sensors Every 3 Months..... 26

 Keep the Unit Out of Direct Sunlight 26

 Troubleshoot LED Indicator Lights 27

Appendix A: Size the Solar System to Power the Cell 2000 29

 Understand How to Maximize Solar Energy 29

 Size the Solar System 29

 Minimum and Maximum Solar PV Array Requirements 30

Appendix B: Product Description, Product Specifications 31

 Product Description..... 31

 Product Specifications..... 32

Appendix C: Calculate Maximum Cable Lengths for Different Motor Load Currents..... 33

Appendix D: Typical Diagram for Cell 2000 Operated Solar Water Pumping System..... 34

 Size the Solar PV Array to Your Specific Motor 34

Terms and Conditions..... 35

 **NOTICE**

This manual is intended to be used as an installation and operation guide. The information in this document is subject to change without notice. No part of this document may be reproduced in any form or by any means without the express written permission of ENFusion™.

INSTALLATION

Task 1: Mount the Cell 2000

The Cell 2000 is an off-grid solar controller that can operate most alternating current (AC) motor loads up to 1HP single-phase/1.5HP three-phase from solar photovoltaic (PV) power. The Cell 2000 has a unique functionality that enables users to match an AC load with solar PV power. By using commercially and locally available AC pumps, the Cell 2000 makes solar water pumping and other solar-powered applications more affordable.

Step One: Decide Best Location

Important Pre-Installation Warnings



WARNING

*Do not ground the positive or negative leads of the PV modules!
Only ground the mounting frames of the PV modules.
Never run the Cell controller when the AC pump is not connected!
It might cause damage to the controller.
If an installed three-phase pump does not start pumping water, switch the positions of any two of the three motor wires. It will change the direction of rotation and it should start pumping water!*

- Contact your ENFusion™ Supplier/Dealer for any service or warranty claims at info@enfusionenergy.com.
- National Electric Code (NEC) takes precedence over suggestions in this manual.

We strongly recommend that the installation data be recorded into the "Installation Notes" (See Figure 16: Installation Notes) and that you keep the manual stored near the unit.

Cell 2000 Requirements for Safe Installation

The Cell 2000 must be installed in a shaded location away from any source of heat and moisture and in an area free of vegetation. Measures must also be made to protect the unit from damage by unauthorized persons, large animals, overgrowth, flooding, or other harm.

The Cell 2000 should not be exposed to direct sunlight. The ideal location for the unit is mounted underneath the solar panels, as our illustrations show.

Cell 2000 Mounting Clearances

- The Cell 2000 should be mounted at least 2 feet (60cm) above the ground when possible.
- A minimum of 10 inches (25cm) of clearance above the Cell 2000 is required for internal access.
- There must not be an obstruction of air flow to the heatsink.

A typical installation on an array structure is shown in Figure 1: Cell 2000 Mounting Clearances.

Figure 1: Cell 2000 Mounting Clearances

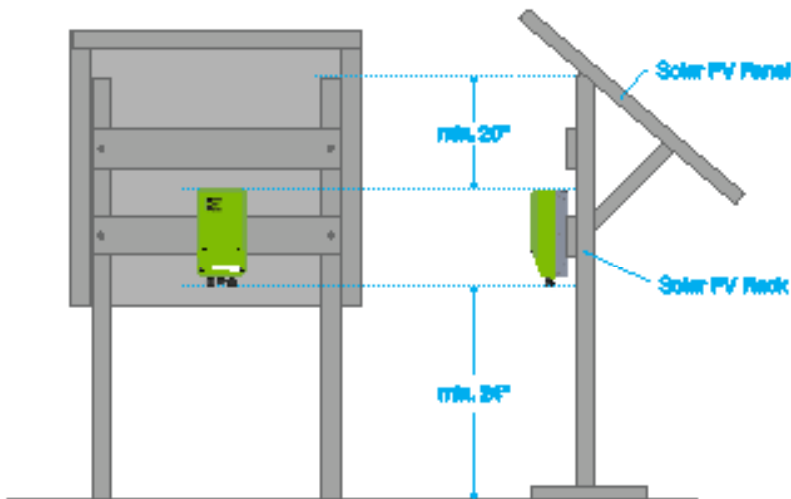

Cell 2000 Dimensions

Dimensions of the Cell 2000 and back panel are shown in Figure 2: Cell 2000 Dimensions, with additional details on how to mount the unit in Figure 3: Back View of Cell 2000 Mounting Bracket and Figure 4: Cell 2000 Unit Mounting Instructions.

Figure 2: Cell 2000 Dimensions

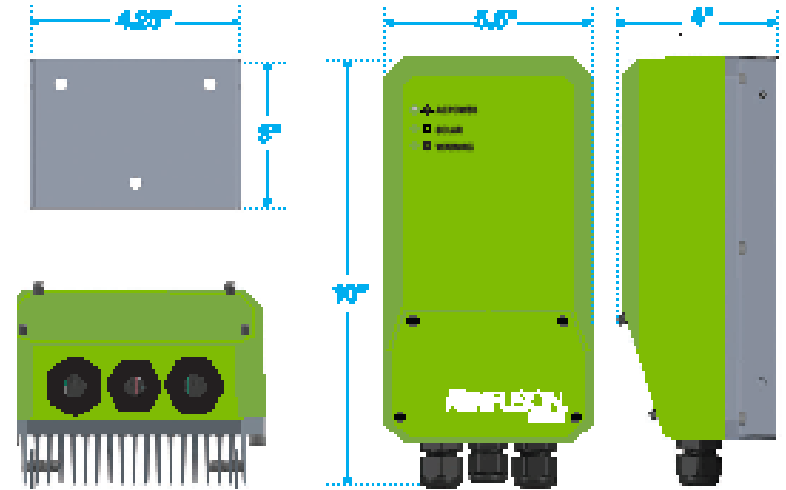

Step Two: Mount the Cell 2000

Cell 2000 Unit Mounting Instructions

The Cell 2000 controller should be mounted on a wall or other vertical surface using the back bracket (See Figure 3: Back View of Cell 2000 Mounting Bracket).

On the back side of the unit there are two set screws (not included) used to hang the unit on the back bracket. More detailed mounting instructions are shown in Figure 4: Cell 2000 Unit Mounting Instructions.

Figure 3: Back View of Cell 2000 Mounting Bracket

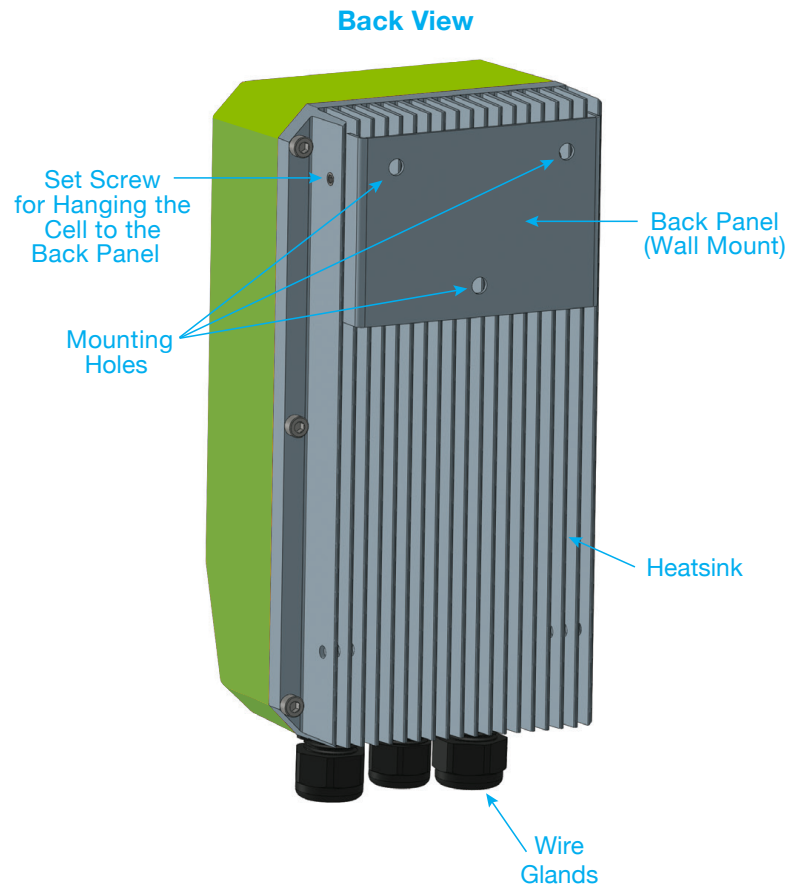
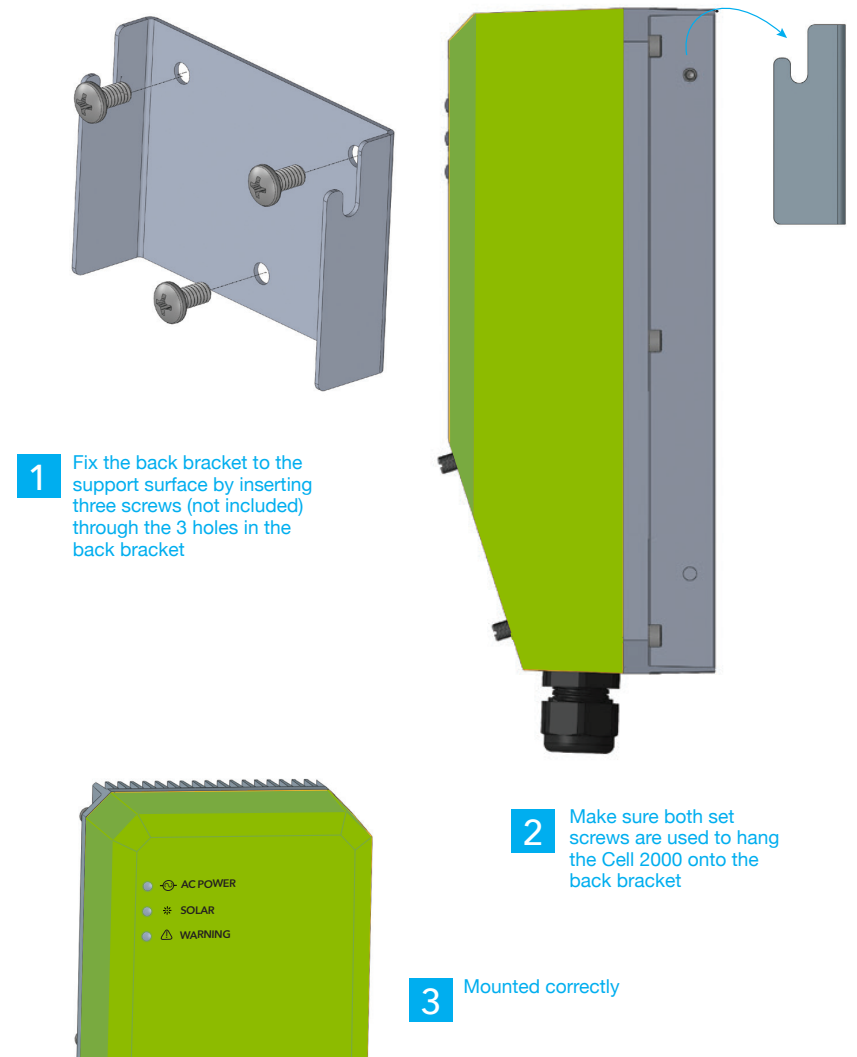

Figure 4: Cell 2000 Unit Mounting Instructions



Task 2: Wire the Cell 2000

Step One: Review Wiring Requirements and Warnings

Installation Requirements:

All electrical installations must be carried out in accordance with local standards and the National Electrical Code (NEC).

Conductor rated current, temperatures, operating conditions and its power loss must be made in accordance with local standards and the National Electrical Code (NEC).

Wiring Warnings

WARNING

*Do not ground the positive or negative leads of the PV modules!
Only ground the mounting frames of the PV modules.
Never run the Cell controller when the AC pump is not connected!
It might cause damage to the controller.
If an installed three-phase pump does not start pumping water, switch the positions of any two of the three motor wires. It will change the direction of rotation and it should start pumping water!*

Step Two: Review System Wiring Diagrams

Review Overview Diagram of Cell 2000 Showing Three Wire Glands

The unit has three cable glands:

- One cable gland for a single/three-phase motor cables (left)
- One cable gland for external sensor data cables (middle)
- One cable gland for solar PV inputs (right side)

Further details about wiring the unit are provided in Figure 5: Overview Diagram of Cell 2000 Showing Three Wire Glands.

Figure 5: Overview Diagram of Cell 2000 Showing Three Wire Glands

Once the door of the enclosure is open, there are three terminal blocks:

- 1 Solar PV Wires
- 2 Motor/Pump Wires
- 3 Pump or Tank Sensor Wires

More information about sensor wiring and DIP switches is provided on pages 11-12.

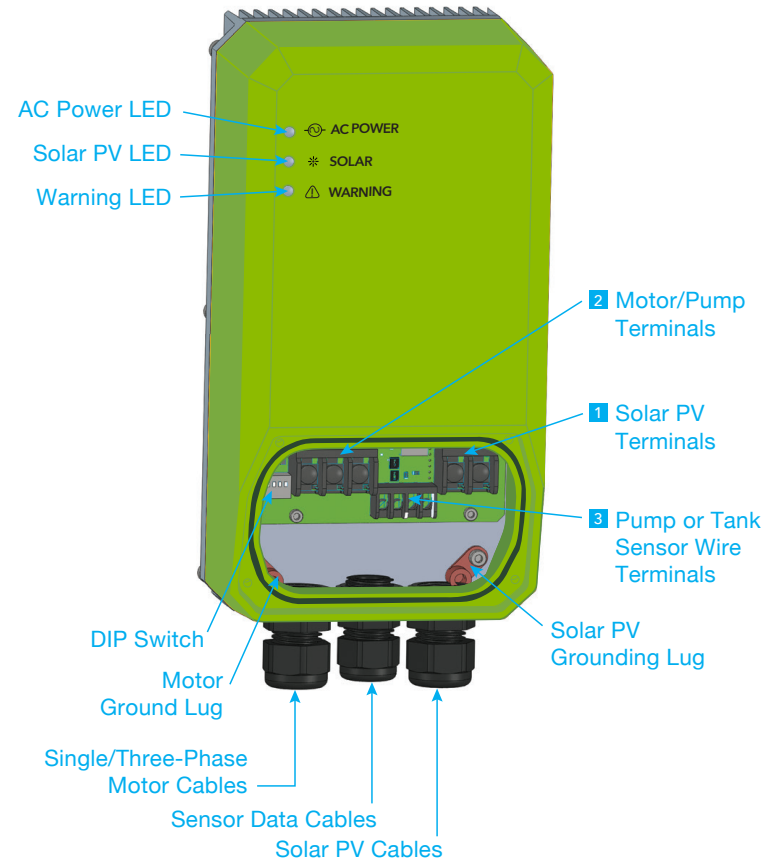

WARNING

Do not modify DIP switch settings until power has been turned off and after 90 seconds have passed for internal voltages to discharge below voltage of 50V! Power must be removed for DIP switch settings to take effect.

Review Cell 2000 System Wiring Diagram

Figure 6: Cell 2000 System Wiring Diagram is a top level wiring diagram illustrating how the various components are wired into the Cell 2000. Review Step One: Review Wiring Requirements and Warnings.

Figure 6: Cell 2000 System Wiring Diagram

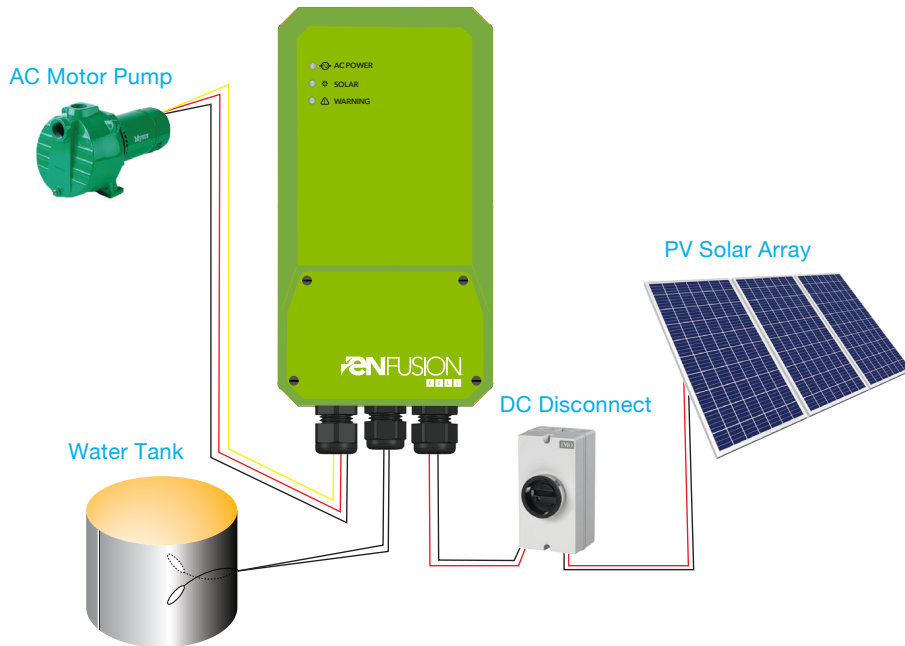

WARNING

Do not ground the positive or negative leads of the PV modules!
Only ground the mounting frames of the PV modules.
Never run the Cell controller when the AC pump is not connected!
It might cause damage to the controller.
If an installed three-phase pump does not start pumping water, switch the positions of any two of the three motor wires. It will change the direction of rotation and it should start pumping water!

Wiring for Single-Phase Motor Loads

- Single-phase motor loads should be wired as shown in Figure 7: Table of Wiring for Single-Phase Motor Loads.
- Single-phase 2-wire motors should be connected to phase A and C, while 3-wire motors should be wired so that common lead is wired to phase A, starting winding to phase B and main winding to phase C. Use DIP Switch 6 for proper single-phase motor selection.

Figure 7: Table of Wiring for Single-Phase Motor Loads

IMPORTANT:

Single-phase 2-wire motor pumps:	Connect to A and C motor terminals of Cell
Single-phase 3-wire motor pumps:	Ph_A: YELLOW wire - common motor lead Ph_B: RED wire - start motor lead Ph_C: BLACK wire - main motor lead

Step Three: Wire to DC (Solar) Sources

Wire to DC Sources as Per Wiring Diagram

Once the Cell 2000 is installed in a shaded location, as shown in Figure 1: Cell 2000 Mounting Clearances, it should be wired to DC (solar) sources.

- Voltage and current levels are defined on Page 32: Product Specifications.
- Please refer to maximum cable lengths in Figure 23: Maximum Input Cable Lengths in Feet (based on 3% voltage drop).

Figure 8: Internal Wiring Diagram to DC (Solar) Sources

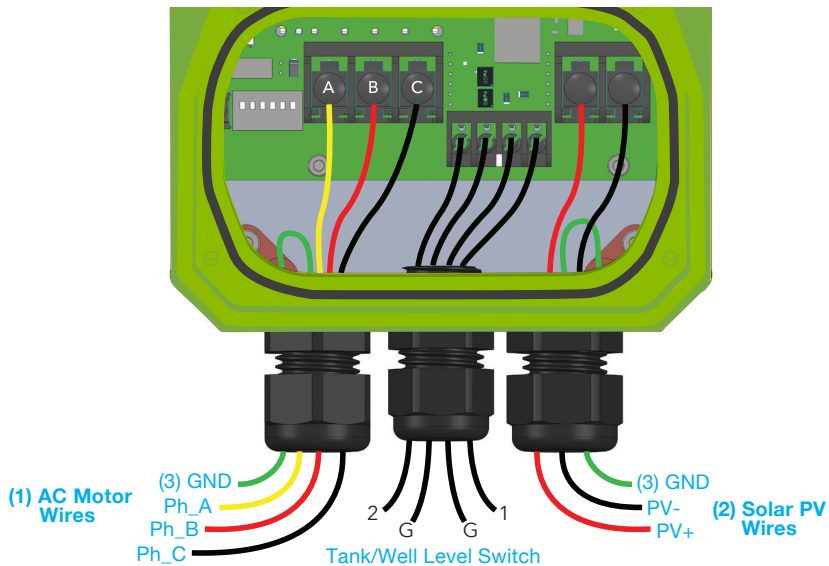

Tighten the Power Conductors

Once the system is wired (per Figure 8: Internal Wiring Diagram to DC [Solar] Sources) the power conductors wired to the terminal blocks inside the Cell 2000 should be tightened with torque values of:

- Power solar PV and motor load conductors: 10 lb-in
- Float switch signal conductors: 8 lb-in

The cable glands (cord grips) on the bottom of the enclosure should be used as shown on Figure 8: Internal Wiring to Diagram to DC (Solar) Sources.

- Solar power wires feed through the right gland
- Float switch/signal wires feed through the middle gland
- Motor load wires feed through the left gland

Step Four: Set Cell 2000 DIP Switch Settings

The Cell 2000 controller can operate most AC motors up to the power limits of the controller: single or three-phase; 50 or 60Hz; 120V or 230V. In order for the Cell 2000 to match the motor specifications the first three DIP switches on the left are used for motor selection (see Set DIP Switches 1, 2, or 3 to Match Your Motor).

The features of a Cell 2000’s DIP Switches are shown in Figure 10: Closeup of DIP Switches. The installer needs access to the DIP switches when configuring the Cell 2000 DIP to match the AC motor load. Setting the DIP switch settings is described in greater detail:

- Figure 11: Set Dip Switches 1, 2, 3 to Match Your Motor
- Figure 12: Set DIP Switches 4 and 5 for Overcurrent Protection
- Figure 13: DIP Switch 6 (If DIP Switch 2 Is Set for Single-Phase Operation)

Configuring DIP switch settings is crucial to the Cell 2000 to recognize the motor (load) and any other parameters or constraints in the application.

NEVER skip DIP switch configuration. It will always apply in one form or another to your application.

WARNING

Do not modify DIP switch settings until power has been turned off and after 90 seconds have passed for internal voltages to discharge below voltage of 50V! Power must be removed for DIP switch settings to take effect.

Figure 9: Location of DIP Switches on Circuit Board

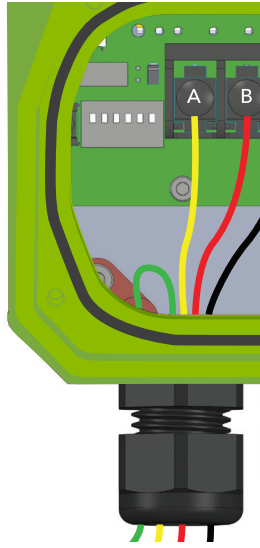
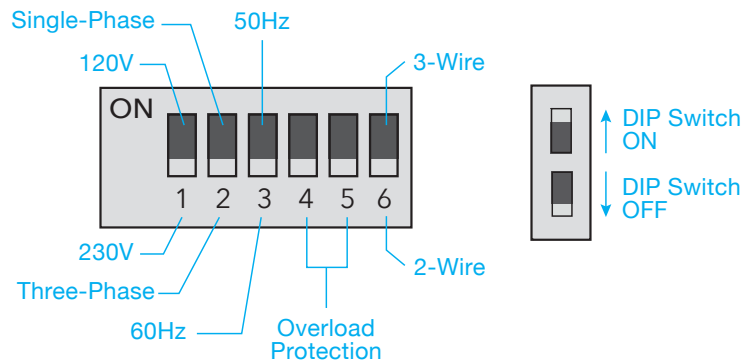

Figure 10: Closeup of DIP Switches



Set DIP Switches 1, 2, or 3 to Match Your Motor

The Cell 2000 controller can operate most AC motors up to the power limits of the controller: single or three-phase; 50 or 60Hz; 120V or 230V. In order for the Cell 2000 to match the motor specifications, the first three DIP switches on the left are used for motor selection:

DIP Switch 1 – 120/230V:

- If switched ON (up – as in Figure 11: Set Dip Switches 1, 2, 3 to Match Your Motor) the unit is configured for 120V pump operation.
- If switched OFF (down) the unit is configured for 230V.

DIP Switch 2 – 1/3 phase:

- If switched ON (up – as in Figure 11: Set Dip Switches 1, 2, 3 to Match Your Motor) the unit is configured for single-phase motor operation.
- If switched OFF (down) the unit is configured for three-phase motor operation.

DIP Switch 3 – 50/60Hz:

- If switched ON (up – as in Figure 11: Set Dip Switches 1, 2, 3 to Match Your Motor) the unit is configured for 50Hz motors.
- If switched OFF (down) the unit is configured for 60Hz motors.

Figure 11: Set DIP Switches 1, 2, 3 to Match Your Motor

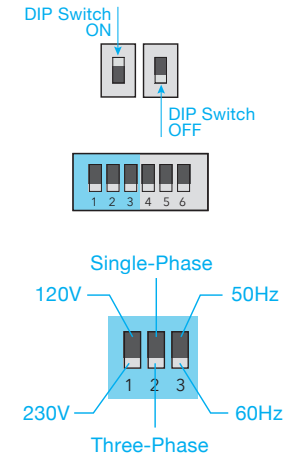

Set DIP Switches 4 and 5 for Overcurrent Protection

DIP Switches 4 and 5 - Overcurrent Protection:

- The Cell 2000 can set over-current protection based on the motor pump and controller combination being used.
- Figure 12: Set DIP Switches 4 and 5 for Overcurrent Protection shows how to set up overcurrent protection using DIP switches 4 and 5.
- The default value of RMS current (when both switches are OFF) is 9A for single-phase and 7A for three-phase.
- DIP switches 4 and 5 are to be used to match or exceed the motor nameplate's SFAMPS in order to protect from overcurrent.

Figure 12: Set DIP Switches 4 and 5 for Overcurrent Protection

DIP Switches	Overcurrent Single-Phase	Protection Three-Phase
	9A	7A
	8A	5.5A
	6.5A	4.5A
	5.5A	3.5A

- For example, if a single-phase motor has SFAMPS: 7A, then DIP switches 4 and 5 have to be set for 8A, as this is the next highest protection current for this motor.
- Configuring Overcurrent Protection also configures automatic Dry Well Protection.
- The Cell 2000 monitors motor amperage for dry well protection, and no other dry well sensor input is needed unless desired.

Set DIP Switch 6 (If DIP Switch 2 Is Set for Single-Phase Operation)

DIP Switch 6 - Single-Phase 2-wire/3-wire:

- Used for setting up the proper mode for single-phase operation.
- This is relevant only when DIP switch 2 is set for single-phase operation.
- The default setting is for single-phase 2-wire motors, when DIP switch 6 is in the OFF (down – as in Figure 13: DIP Switch 6 [If DIP Switch 2 Is Set for Single-Phase Operation]) position.
- For 3-wire single-phase motors, DIP switch 6 should be in the ON (up) position.

Figure 13: DIP Switch 6 (If DIP Switch 2 Is Set for Single-Phase Operation)

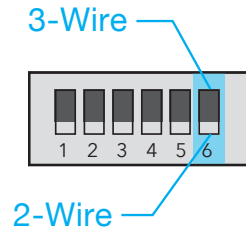

Install Cover Door and Tighten It

When all conductors are wired into the controller the cover (enclosure door) should be replaced and tightened using the cover screws to 2-3 in-lb or equivalent.

Step Five: (Optional) Set Cell 2000 Sensor Settings

Remote Turn On/Off With Digital Input or Standard Float Switch

The Cell 2000 controller can be remotely turned ON or OFF by using a digital input or by using a standard float switch. There is a float switch terminal block where digital signal wires are connected.

- If Digital Inputs 1 and COM experience a short circuit the Cell 2000 automatically turns off.
- Similarly, if Digital Input 2 and COM experience an open circuit the Cell 2000 automatically turns off.
- There are numerous remote sensors that can be used: float switch, pressure switch, flow switch, water level sensor, dry run protection, etc. Ask your dealer about configuring sensors and switches for your application.

Figure 14: Example of "Water Tank Full" and "Well Empty"

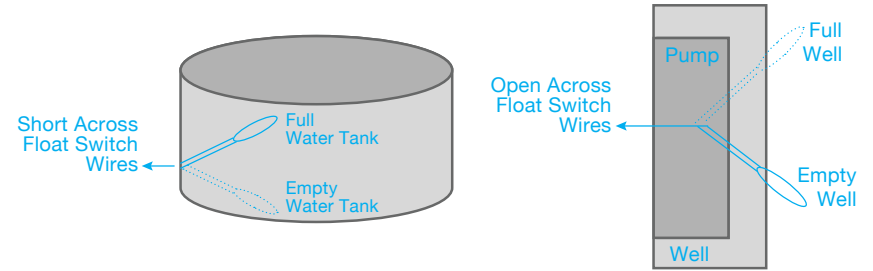

A typical example of how tank and well switch signals can be used with a digital input port is shown in Figure 14: Example of "Water Tank Full" and "Well Empty".

- For a tank application, if the active wire is connected to Position 1 and the return wire (usually black) is connected to Position COM, then the Cell 2000 will stop the pump when the tank gets full because terminals 1 and COM will be "shorted" (active short). This turns off the Cell 2000. See Figure 15: Tank/Well Float Switch.
- For a well application, if the active wire is connected to Position 2 and the return wire (usually black) is connected to Position COM, then the Cell 2000 will stop the pump when the well runs out of water because terminals 2 and COM will be "open" (active open). This turns off the Cell 2000.

Figure 15: Tank/Well Float Switch

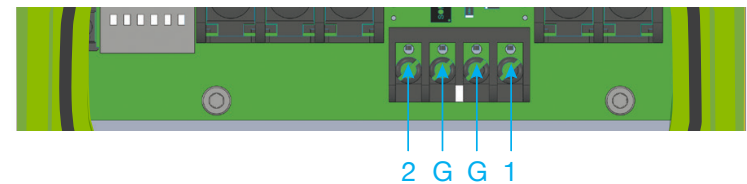

Task 3: Complete Installation Notes

After Installation, Complete Installation Notes

We strongly recommend that you take an extra bit of time to fill out the installation notes (See Figure 16: Installation Notes) with valid data once installation is complete.

When you call our technical support, we will ask you for this information. If you have this installation data available you will have a faster and more accurate troubleshooting process. It's hard to keep track of this information once installation is complete.

Figure 16: Installation Notes

Date Installed: _____

Serial No. (Spec Label): _____

Installer: _____

Phone: _____

Location of Installation: _____

Pump Manufacturer / Model No.: _____

Motor: HP, V, ph, SF Amps: _____

Well Depth: (m/ft) _____

Flow Rate: (lpd/gpd) _____

AC Source Voltage Level: _____

PV Panel Manufacturer / Model No.: _____

No. of Solar PV Panels in Series: _____

Tech Support Hotline: 877-230-7501

Keep This Manual With Your Cell 2000 Unit

We recommend that you keep the manual accessible and located close to the unit. If you have a protected location keep the manual with the unit. If not, keep it easily accessible in the office.

CONFIGURATION

Task 4: Configure the Cell 2000

Step One: Size the Solar Panel Array to Motor Load Power Requirements

- The Cell 2000 can power both single and three phase motors.

When sizing the solar panel array for the Cell 2000 it is necessary to know the motor load power requirements.

The general recommendation is to size the solar PV system capacity to at least match the motor power requirements.

- To do so, it is important to know the motor power when sizing the solar system.
- Contact your dealer for solar sizing for your specific motor.

OPERATION

Task 5: Initial Cell 2000 Startup

Step One: Start Cell 2000 for the First Time

Once the Cell 2000 controller is wired to the solar source and a motor load and the DIP switches settings are configured to match the motor specification, then the Cell 2000 is ready for operation.

Figure 17: Typical Wiring for Cell 2000 Operated Solar Water Pumping System

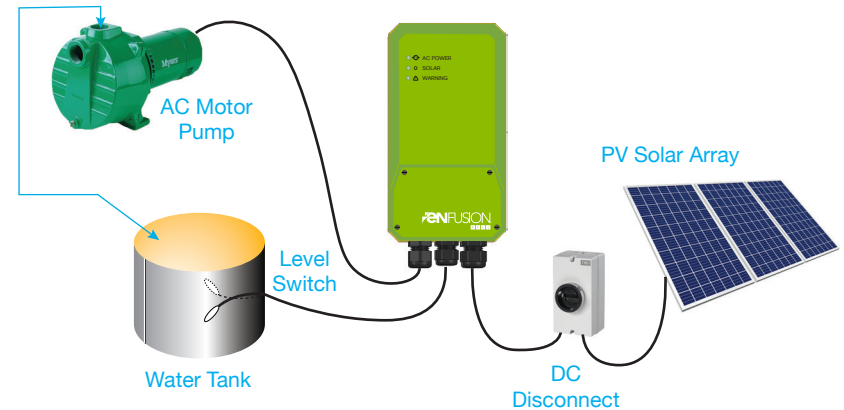

When starting the Cell 2000 for the first time:

1. While the Cell 2000 is still de-energized configure the DIP switches per the AC motor load of the connected device (See Figure 11: Set Dip Switches 1, 2, 3 to Match Your Motor). After DIP switches are configured, turn ON the toggle switch and replace the door. Make sure you properly tighten all four captive door screws so that the door seals.
2. Power up the Cell 2000 from solar PV by switching the solar DC disconnect to the ON position (See Figure 17: Typical Wiring for Cell 2000 Operated Solar Water Pumping System). All LEDs will light up, and after a few seconds the Cell 2000 will try to start the pump, indicated by a blinking green light, and upon starting the green LED will remain ON.
3. If there is not enough solar power available the middle LED will blink yellow indicating insufficient solar power to start the motor load. During start-up mode the Cell 2000 soft starts a 60Hz motor/pump from a standstill to 40Hz operation in 1 second and then the Maximum Power Point Tracking (MPPT) algorithm takes over, increasing the motor to 60Hz operation during full sunlight. This optimizes the motor/pump speed to match available power from the solar PV source. For 50 Hz motors, the Cell 2000 soft starts to 35Hz within one second and then switches to MPPT control.

Step Two: Understand Meaning of Cell 2000's LED Lights

Four LEDs are used to indicate the Cell 2000 controller's operation (See Figure 18: LED 1 - AC Load Is On, and Figure 19: LED 2 - Solar Is On).

Motor Is Properly Connected

Figure 18: LED 1 - AC Load Is On

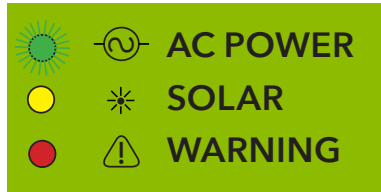

If the motor is properly connected, the Cell 2000 will begin the startup procedure. The green AC LOAD LED (See Figure 18: LED 1 - AC Load Is On) will have a solid green light and the motor will start running.

The Cell 2000 immediately performs MPPT operation over the solar PV source. The MPPT operating range is 30 to 60Hz for 60Hz motors and 25 - 50Hz for 50Hz rated motors.

Cell 2000 Overload Protection

The Cell 2000 has built-in overload protection. If a connected motor has a power level higher than the Cell 2000 limitations:

- It first slows down and tries to run the motor at a lower power level.
- If the motor power continues to be outside the power range of the Cell 2000 it will shut off the motor operation.
- If there is not enough solar power, the unit's SOLAR LED light will blink yellow as shown in Figure 19: LED 2 - Solar Is On.
 - This usually happens in the early morning or late evening, or during overcast weather.
 - The Cell 2000 controller will try to start the motor once every minute.
 - Each attempt will be indicated by the blinking green LED. If there is not enough solar production from the solar panels the yellow LED will start blinking again.

Figure 19: LED 2 - Solar Is On

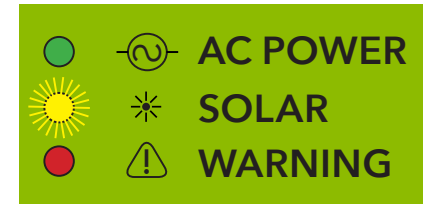

Step Three: Manually Shut Down Cell 2000 Operation

To stop the Cell 2000's operation the DC Disconnect should be used (See Figure 17: Typical Wiring for Cell 2000 Operated Solar Water Pumping System). Once in the OFF position the Cell 2000 will automatically stop the motor's operation.

Understanding Automatic Shutdown of Cell 2000

Automatic Shutdown With Tank or Well Float Switch

If a tank or well float switch is used (See Figure 14: Example of "Water Tank Full" and "Well Empty") when the tank becomes full or the well becomes empty the Cell 2000 will stop its operation and the WARNING LED will blink red.

Automatic Shutoff Due to Temperature

The WARNING LED will be solid red if the temperature of the Cell 2000 rises above 80°C at which point the Cell 2000 will stop operating until the temperature drops. This can happen if the unit is exposed to direct sunlight, which should be avoided.

Power Deration Mode

- If the Cell 2000 gets too hot during normal operation it will switch to Power Deration mode, limiting the maximum power that is transferred to the motor load.
- During that time the AC LOAD LED will be solid green and the WARNING LED will be solid red.
- If the unit cools down to a regular operating temperature it will automatically continue operation without the thermal deration.
- If the temperature of the Cell 2000 continues to increase it will eventually stop operating, at which point the WARNING LED will be solid red.

MAINTENANCE

Task 6: Perform Recommended Maintenance

Inspect Every Three Months

The Cell 2000 unit is designed to operate autonomously. However, we suggest regular inspections every 3 months.

Maintain Optimal Operational Conditions

Keep Clear of External Obstructions

- If there are any external obstructions that prevent proper cooling of the heatsink area please remove them to make sure nothing blocks the air flow from the bottom of the device.

Don't Operate in Freezing Conditions

- If the Cell 2000 operates in an area where the pump experiences freezing temperatures make sure to turn the device OFF so it does not try to run the water pump in icy conditions. This may lead to deadheading on the pump.

Check External Sensors Every 3 Months

- Check external sensors every 3 months: float switch, pressure switch, etc.

Keep the Unit Out of Direct Sunlight

- Cell 2000 should be installed and kept in a shaded location.

Troubleshoot LED Indicator Lights

If there is any issue with the unit, different combinations of LED's will light up and/or flash to indicate the malfunction.

The following two charts explain the various Indicator Light Combinations (See Figure 20: Chart Summarizing All LED Indicator Light Combinations, and Figure 21: Chart Explaining Meaning of LED Indicator Light Combinations).

Figure 20: Chart Summarizing All LED Indicator Light Combinations

AC LOAD	SOLAR	WARNING	MODE
ON	ON	ON	- Unit is OFF
FLASHING	OFF	OFF	- Startup
ON	OFF	OFF	- Running
OFF	FLASHING	OFF	- Standby
OFF	OFF	FLASHING	- Float switch
OFF	OFF	ON	- Over temperature
ON	OFF	ON	- Power deration
FLASHING	OFF	FLASHING	- Over current
OFF	FLASHING	FLASHING	- Short/Open circuit
FLASHING	FLASHING	FLASHING	- Dry well protection

Figure 21: Chart Explaining Meaning of LED Indicator Light Combinations

OFF Mode	Cell toggle switch is in the OFF position.
Startup Mode	Cell is in the process of starting the motor pump.
Running Mode	Cell is running the motor pump.
Standby Mode	There is not enough power from the solar PV panels for Cell to start the motor.
Float Switch Mode	Cell is turned OFF as a result of input from one or more external sensors that are connected to the digital input.
Over Temperature Mode	Cell stops operation when the temperature of the inside unit exceeds 80°C/176°F.
Power Deration Mode	Cell still operates but with reduced power throughout due to increased operating temperature, or if load is connected with current higher than Over Current Protection DIP Switches 6 and 7.
Over Current Mode	Cell stops operation when it detects high current on the motor terminals. This can also be due to a short circuit event if the unit is mis-wired. Requires manual restart by cycling power to the unit.
Open Circuit Mode	Cell will not start operation if the motor wiring does not align with DIP switch configuration.
Dry Well Protection	Cell detects dry well condition and ceases pump operation, which is restored after 30 minutes. If dry well indication appears faulty, check that Over Current Protection DIP Switches 4 and 5 are configured correctly.

Appendix A: Size the Solar System to Power the Cell 2000

Understand How to Maximize Solar Energy

Size the Solar System

Sizing the solar system to power the Cell 2000 and a given motor load (pump, compressor, fan, etc.) is based on the power requirement of the motor load, motor phase, daily duty cycle of the system and installation location. Motor load requirements can be obtained from the motor nameplate; look for SFAMPS.

- Three-phase motor loads will typically require less solar PV capacity than single-phase loads due to higher electrical efficiency.
- Hence, three-phase pumps are more cost effective because they require less solar PV power.
- Single-phase motor loads with running capacitors (also called split-phase) will also require higher solar PV power at startup than their three-phase counterparts.
- Service Factor (SF) can also vary between motor manufacturers. A higher SF may require more PV solar power.

For off-grid solar pumping applications, the main requirement is either total daily pumped water or the total amount of time the pump will operate from solar power.

Figure 22: Sizing Solar PV Power With the Cell 2000 Controller

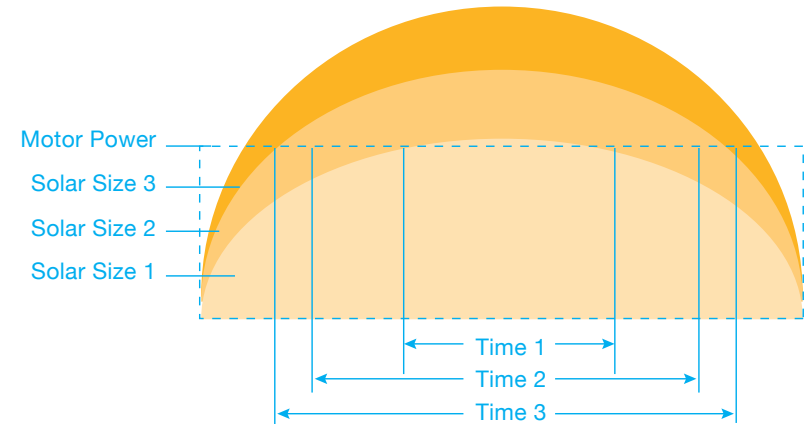

Figure 22: Sizing Solar PV Power With the Cell 2000 Controller shows how three different solar capacities (solar power wattage) are affecting total daily pumping duration. Motor power is shown by the dashed line.

- If Solar Size 1 results in Time 1 for a given pump power, then by adding solar power to Solar Size 2 the pumping time increases significantly.
- However, same solar power addition to Solar Size 2 results in Solar Size 3, but incremental time between Time 3 and 2 is not the same as between Time 2 and 1.
- Therefore, a linear solar power capacity increase **does not** result in a linear daily pumping time increase. Additional solar capacity results in decreasing returns for increased pumping time.

Minimum and Maximum Solar PV Array Requirements

Additionally, it is important to note the minimum and maximum solar PV array requirements when sizing solar for a given pump using the Cell 2000.

- Configuring solar PV capacity will vary based on location of the installation (i.e. different solar irradiances at different latitudes).
- For a more detailed solar PV configuration, please contact the ENFusion™ Sales Team or your local dealer. Be ready to provide the motor load nameplate information as well as installation site location and application requirements of the desired daily duty cycle.

Appendix B: Product Description, Product Specifications

Cell 2000 Product Description

The Cell solar controller is a universal, high performance, variable speed motor controller for solar applications using single-phase and three-phase AC loads in a power range from 1/3 HP to 1.5 HP.

The Cell controller is suitable for a variety of applications, including:

- Livestock water supply
- Small scale irrigation
- Industrial farming ventilation
- Water transfer and evaporation
- Village water supply
- Aquaculture and aeration
- Swimming pool filtration

As a standalone AC motor/pump/compressor/fan solar controller, the Cell enables free solar power for a vast number of AC devices. The Cell can power new and previously installed (retrofit) AC motors. Please consult with a dealer to size the solar arrays when using the Cell.

For new installations, motor selection can also optimize the system economics. 230V three-phase motors are the most electrically efficient and require the least amount of solar, followed by 115V three-phase, 230V single-phase and 115V single-phase in descending order of efficiency.

NOTE: Motors controlled by the Cell do not require separate motor controls. The Cell was designed to be universal for most inductive motors while being mindful of some basic design limitations:

The Cell may not operate 2-wire, single-phase motors that use switching devices to start. This includes, but is not limited to, 2-wire starting capacitors, both centrifugally switched and BIAC switched. Ask about ENFusion's Accessory Power Cable to retrofit 2-wire surface motors.

- The Cell can run motors with Service Factor Amps of 9A or less for single-phase motors, and 7A or less for three-phase motors. Please contact ENFusion™ for more information on particular motors.
- Generally, single-phase motor up to 1 HP will operate well.
- Generally, three-phase motor up to 1.5 HP will operate well.
- The Cell does not power Direct Current (DC) permanent magnet or Brushless DC (BLDC) motors.
- The Cell will replace the control box for 3-wire motors. The Cell will operate 2-wire motors with Permanent Split Capacitors (PSC).
- The Cell will replace the manufacturer's motor controller when installed on a Variable Speed Drive (VSD) or a Variable Frequency Drive (VFD) submersible pump motor.
- The Cell will not operate submersible motors with 2-wire starting capacitors, including Franklin Electric 2-wire submersibles and Grundfos 2-wire submersibles. ENFusion™ offers accessory cables to retrofit most 2-wire starting capacitor surface motors.

Cell 2000 Specifications

Input Specification:

- Minimum Operating Voltage: **100V (FOR 115V), 150V (FOR 230V)**
- Maximum Solar Open Circuit Voltage: **400V**
- Maximum Solar PV Current in Series: **12A**
- Earth-ground connected to chassis

Output Specification:

- Maximum Output Current: **9A (SINGLE-PHASE MOTORS)**
- Maximum Output Current: **7A (THREE-PHASE MOTORS)**
- Maximum Power Sustained: **2000W**

Protections:

- Short-circuit, ground-fault, over temperature, over-load, over voltage, over current, and solar input reverse polarity protection
- Automatic dry well protection and pump locked rotor protection

Integral solid state short circuit protection does not provide branch circuit protection. Branch circuit protection must be provided in accordance with the National Electrical Code (NEC) and any additional local codes.

Technical Specifications

ELECTRICAL

Solar PV operating voltage range: **100-380V**
 Max PV panels open circuit voltage: **400V**
 Solar PV rated current per channel: **12A**
 Single-phase max AC motor power: **9A**
 Three-phase max AC motor power: **7A**

MECHANICAL

Degree of protection: **NEMA4/IP66**
 Enclosure material: **CAST ALUMINUM**
 Operating temperature: **-40°C TO 50°C**
 Dimensions: **10" X 5.5" X 4"**
 Solar terminal: **AWG#10-14**
 Motor terminal: **AWG#10-14**
 Sensor terminal: **AWG#14-22**
 Cooling: **PASSIVE/NO FAN**



Carefully check the motor load specifications and solar PV array maximum power point voltage to setup the system properly using this manual!

Environmental – Compliance with IEC 60068

- IEC 60068-2-2 – Cold
- IEC 60068-2-14 – Change of Temperature
- IEC 60068-2-2 – Dry Heat
- IEC 60068-2-30 – Damp Heat

Appendix C: Calculate Maximum Cable Lengths for Different Motor Load Currents

Once the Cell 2000 is installed in a shaded location (Figure 1: Cell 2000 Mounting Clearances) it can be wired to DC (solar) sources.

Maximum cable lengths for 115 and 230V for different motor load currents are shown in Figure 23: Maximum Input Cable Lengths in Feet (Based On 3% Voltage Drop).

Figure 23: Maximum Input Cable Lengths in Feet (Based On 3% Voltage Drop)

Motor Load [A]	Nominal Voltage [V]	AWG Copper Wire Sizes 90°C (194°F) insulation [ft]				
		16	14	12	10	8
4	115	110	165	270	400	600
	230	220	330	540	800	1200
6	115	70	110	175	275	400
	230	140	220	350	550	800
8	115	55	85	135	200	300
	230	110	170	270	400	600

IMPORTANT: Use copper conductors only!

This unit was evaluated for temperature rating of 60/75°C on power field wiring terminals.

Appendix D: Typical Diagram for Cell 2000 Operated Solar Water Pumping System

Size the Solar PV Array to Your Specific Motor

To size the solar PV array to your specific motor please consult with your local dealer or ENFusion™ tech support. A typical diagram for a Cell 2000 operated solar water pumping system is shown in Figure 24: Typical Diagram for Cell 2000 Operated Solar Water Pumping System.

The solar PV array should be connected to the Cell 2000 controller via the integrated DC Disconnect. The Cell 2000 controller should be installed in the shade (potentially mounted under the PV array) and away from the direct sun.

Figure 24: Typical Diagram for Cell 2000 Operated Solar Water Pumping System

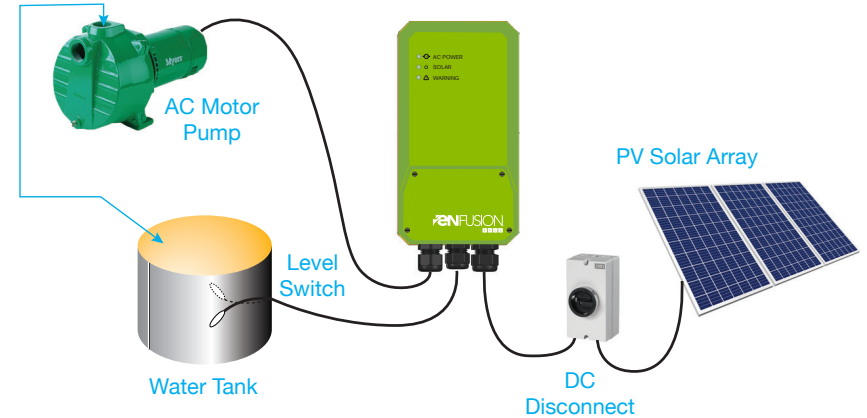

The Cell 2000 can accept up to two digital sensor inputs.

- For example, in solar water pumping applications an optional float switch can be connected to the Cell 2000 to monitor when a water tank is full, or a pressure switch can be used in combination with a pressure tank.
- The Cell 2000 off-grid solar controller is unique because it can run single or three-phase AC motors, 115 or 230V, and 50 or 60Hz.

Standard Terms and Conditions

enfusionenergy.com

THIS DOCUMENT CONTAINS PREMIER ENERGY HOLDINGS, INC., AND ALL OF ITS SUBSIDIARIES (COLLECTIVELY REFERRED TO AS "PEH"), NORTH AMERICAN STANDARD LIMITED WARRANTY, GENERAL SALES POLICIES AND CONTROLLING TERMS AND CONDITIONS. THIS NORTH AMERICAN STANDARD LIMITED WARRANTY, GENERAL SALES POLICIES AND CONTROLLING TERMS AND CONDITIONS SHALL NOT BE ALTERED OR AMENDED EXCEPT PURSUANT TO AN AUTHORIZED PEH EXTENDED WARRANTY.

*PEH Standard Terms & Conditions are subject to change at any time.
The latest version is available at ENFusionEnergy.com.*

EFFECTIVE DATE AND NO AGREEMENT OR AMENDMENTS

This document and its provisions are effective as of February 1, 2022, and valid until further written notice from PEH. This document and its provisions shall supersede all pre-existing sales policies, terms and conditions, and standard limited warranties issued by PEH, whether in writing or orally. This document does not reflect an offer or an agreement to sell PEH products to any person or entity and should not be construed as such.

GENERAL SALES POLICIES AND CONTROLLING TERMS AND CONDITIONS

PEH OBJECTS TO, AND SHALL NOT BE BOUND BY, ANY ADDITIONAL OR DIFFERENT TERMS OR CONDITIONS, WHETHER PRINTED OR OTHERWISE AND REGARDLESS OF WHETHER SUCH ADDITIONAL TERMS OR CONDITIONS ARE IN PURCHASER'S PURCHASE ORDER OR IN ANY OTHER COMMUNICATION FROM PURCHASER TO PEH.

The terms and conditions appearing in this agreement together with PEH's standard or custom product specifications (if applicable), constitute the entire agreement between PEH and Purchaser. PEH objects to, and shall not be bound by, any additional or different terms, whether printed or otherwise and whether in Purchaser's purchase order or in any other communication from Purchaser to PEH, unless PEH has specifically agreed in writing to those additional or different items. Prior courses of dealing, trade usage and verbal agreements not reduced to a writing signed by PEH to the extent they differ from, modify, add to, or detract from this agreement shall not be binding upon PEH. There are no other agreements, promises or understandings, either verbal or written, which are not fully expressed in this agreement. No statements, recommendations or assistance by either party have been relied upon by either party or shall constitute a waiver by either party of any of the provisions hereof. This agreement may be amended or altered only if agreed to in writing, signed by the party against which any such amendment or alteration is asserted.

- a. Acceptance and Payment PEH reserves the right to reject and refuse to process a purchase order for any reason whatsoever. If a Purchase Order (PO) or a line item contained in a PO is canceled by the Purchaser within five (5) days after PO acceptance by PEH, PEH reserves the right to apply cancellation charges of up to twenty percent (20%) of the invoice price of the canceled item(s).

The due date of payment shall be measured from the invoice date. Terms are net

thirty (30) days from date of invoice of each shipment, unless otherwise stated. Any portion of the purchase price which is not paid in accordance with applicable payment terms shall accrue interest at a rate equal to one and one-half percent (1 1/2 %) per month or the highest rate allowed by law, plus any attorney fees and other costs associated with collections. PEH shall apply payments received against outstanding invoices and/or interest charges at its discretion.

- b. Prices and Taxes All prices and discounts are subject to change by PEH, with or without prior notice. Prices and discounts applicable to unshipped quantities of existing purchase orders, as well as to new purchase orders, shall be those in effect at the time of shipment. A representation by Purchaser of facts, upon which PEH relies in basing applicable discount or term of sale, shall be taken as a representation that such facts are true; and PEH shall have the right to revise any price or discount, including products already shipped, invoiced, or paid, should such representations be untrue. All prices are net of, and do not include, any federal, state, or local income, property, sales, use, excise, value-added, or other taxes, all of which shall be the responsibility of, and paid by, purchaser.

- c. Quotations No price quotations for PEH products shall be binding on PEH unless confirmed in writing by PEH. Prices so quoted will be binding on PEH for thirty (30) days from the date of the price quotation unless noted in the quotation by PEH. Price quotations do not include accessories or components not manufactured by PEH. Clerical errors on any price quotations are subject to correction by PEH. Quotations are subject to change by PEH with notice to Purchaser.

- d. Delivery Shipments may be made by common carrier, unless otherwise specified. Special arrangements, such as air freight, parcel shipment, overnight delivery and special packaging requirements must be specifically requested by Purchaser and, if agreed to in writing by PEH, will be at Purchaser's expense.

Any dates or schedules specified for the delivery of goods covered hereby are approximate only and are based upon then existing conditions and/or conditions reasonably anticipated through each shipping date. In addition to the limitation on damages described herein, PEH shall not, under any circumstances be liable for any loss, cost, expense, delay, damage, inconvenience, or consequential damages for failure (however caused) to meet a specific shipping date, or for any delay, loss, or damage in transit, or due to the unavailability of sufficient products to fill a purchase order. PEH reserves the right to allocate available inventories among its customers, including Purchaser, in the event that such inventories are inadequate to meet demand.

Title to the product shipped shall pass to Purchaser when PEH delivers such goods (i) to the carrier for delivery to Purchaser or (ii) to the dock for export shipments to Purchaser, and all risks of damage, loss, or delay shall thereupon pass to Purchaser. PEH shall promptly, after shipment, notify Purchaser that the goods have been delivered to the carrier or to the dock and shall furnish Purchaser with all documents, if any that are required to enable Purchaser to obtain possession of the product.

STANDARD LIMITED WARRANTY

Except as set forth in an Extended Warranty, for two (2) years from the date of purchase, PEH hereby warrants to the purchaser ("Purchaser") of PEH's products that, for the applicable warranty period, the products purchased will (i) be free from defects in workmanship and material at the time of shipment, (ii) perform consistently with samples previously supplied and (iii) conform to the specifications published or agreed to in writing between the purchaser and PEH. This limited warranty extends only to products purchased directly from PEH. If a product is purchased other than from an authorized distributor, dealer or directly from PEH, such product must be installed by a PEH Certified Installer for this limited warranty to apply. This limited warranty is not assignable or transferable to any subsequent purchaser or user.

e. **THIS LIMITED WARRANTY IS IN LIEU OF ALL OTHER WARRANTIES, WRITTEN OR ORAL, STATUTORY, EXPRESS, OR IMPLIED, INCLUDING ANY WARRANTY OF MERCHANTABILITY OR FITNESS FOR A PARTICULAR PURPOSE. PURCHASER'S SOLE AND EXCLUSIVE REMEDY FOR PEH'S BREACH OF ITS OBLIGATIONS HEREUNDER, INCLUDING BREACH OF ANY EXPRESS OR IMPLIED WARRANTY OR OTHERWISE, UNLESS PROVIDED ON THE FACE HEREOF OR IN A WRITTEN INSTRUMENT MADE PART OF THIS LIMITED WARRANTY, SHALL BE FOR THE PURCHASE PRICE PAID TO PEH FOR THE NONCONFORMING OR DEFECTIVE PRODUCT OR FOR THE REPAIR OR REPLACEMENT OF NONCONFORMING OR DEFECTIVE PRODUCT, AT PEH'S ELECTION. ANY PEH PRODUCT WHICH PEH DETERMINES TO BE DEFECTIVE WITHIN THE WARRANTY PERIOD SHALL BE, AT PEH'S SOLE OPTION, REPAIRED, REPLACED WITH FACTORY REFURBISHED OR NEW PRODUCT WITH A MODEL OR VERSION NO OLDER THAN THAT OF ORIGINALLY PURCHASED PRODUCT, OR A REFUND OF THE PURCHASE PRICE PAID. REPAIR OR REPLACEMENT OF PRODUCT DOES NOT EXTEND THE ORIGINAL WARRANTY PERIOD.** Some states do not allow limitations on how long an implied warranty lasts, therefore, the limitations and exclusions relating to the products may not apply.

f. **WITHOUT LIMITING THE GENERALITY OF THE EXCLUSIONS OF THIS LIMITED WARRANTY, PEH SHALL NOT BE LIABLE TO THE PURCHASER OR ANY THIRD PARTY FOR ANY AND ALL (i) INCIDENTAL EXPENSES OR OTHER CHARGES, COSTS, EXPENSES (INCLUDING COSTS OF INSPECTION, TESTING, STORAGE, OR TRANSPORTATION) OR (ii) DAMAGES, INCLUDING CONSEQUENTIAL, SPECIAL DAMAGES, PUNITIVE OR INDIRECT DAMAGES, INCLUDING, WITHOUT LIMITATION, LOST PROFITS, LOST TIME AND LOST BUSINESS OPPORTUNITIES, REGARDLESS OF WHETHER PEH IS OR IS NOT SHOWN TO BE AT FAULT, AND REGARDLESS OF WHETHER THERE IS OR THERE IS NOT SHOWN TO HAVE BEEN A DEFECT IN MATERIALS OR WORKMANSHIP, NEGLIGENCE IN MANUFACTURE OR DESIGN, OR A FAILURE TO WARN.**

PEH's liability arising out of the sale or delivery of its products, or their use, whether based upon warranty contract, negligence, or otherwise, shall not in any case exceed the cost of repair or replacement of the product and, upon expiration of any applicable warranty period, any and all such liability shall terminate. Without limiting the generality of the exclusions of this limited warranty, PEH does not warrant the adequacy of any specifications provided directly or indirectly by a purchaser or that PEH's products will perform in accordance with such specifications.

This limited warranty does not apply to any products that have been subject to misuse (including use in a manner inconsistent with the design of the product), abuse, neglect, accident or improper installation or maintenance, or to products that have been altered or repaired by any person or entity other than PEH or its authorized representatives. Unless otherwise specified in an Extended Warranty authorized by PEH for a specific product or product line, this limited warranty does not apply to performance caused by abrasive materials, corrosion due to aggressive conditions or improper voltage supply.

With respect to PEH products, the following conditions automatically void this limited warranty:

1. Lightning damage (often referred to as high voltage surge damage).
2. Electrical failures due to the use of non-approved overload protection.
3. Unauthorized disassembly.

MISCELLANEOUS

In compliance with Laws, Ordinances and Regulations PEH shall use reasonable efforts to cause the products to comply with federal safety, health and environmental regulations and insurance codes. However, PEH shall not be responsible for compliance of the products with local interpretations of such federal regulations or insurance codes, nor with any local laws, ordinances, codes and/or regulations which may at any time be in effect at any location where the products are to be used, unless such responsibility shall be expressly assumed by PEH in writing.

Change of Design

PEH shall be entitled to make any and all changes in details of design, construction or arrangement of the product as PEH in its sole discretion determines will constitute an improvement upon the product or any specifications or designs previously furnished to the Purchaser.

PEH Remedies

In addition to and notwithstanding any other remedy to which PEH may be entitled by law, in the event of Purchaser's breach of its obligations hereunder, or if Purchaser should cancel a purchase order, in whole or in part, or refuse to accept the products shipped hereunder, or wrongfully rejects or revokes its acceptance of products shipped that conform to a purchase order, Purchaser shall pay for, and PEH shall be entitled to recover from Purchaser, all special engineering, design, tooling, manufacturing, storage, or transportation costs incurred in connection with PEH's performance of the purchase order.

Infringement

With respect to PEH's own standard designs and specifications, or specialty products which PEH has engineered and designed, PEH shall defend, indemnify and hold Purchaser harmless from and against any loss, damage, cost or expense arising out of any third-party claims for patent or trademark infringement relating to such products, so long as Purchaser promptly notifies PEH in writing of any such claim and gives PEH such authority, information and assistance as PEH may request in connection with the defense thereof.

Purchaser shall defend, indemnify and hold PEH harmless from and against any loss, damage, costs or expenses arising out of any claims of patent or trademark infringement relating to products manufactured by PEH in accordance with any designs or specifications furnished by Purchaser.

Special Tooling

Any special tools, dies, jigs, molds, or other equipment manufactured or purchased by PEH, regardless of whether included as part of PEH's pricing, shall remain PEH's exclusive property.

Confidentiality

All commercial, financial or technical information furnished by PEH shall be considered confidential and Purchaser shall not disclose any such information to any other person or use such information itself for any purpose other than the re-sale or the intended use of the products. This Section shall apply to drawings, specifications or other documents prepared by us.

Unless otherwise agreed in writing, no information disclosed in any manner or at any time by Purchaser to PEH shall be deemed secret or confidential, and Purchaser shall have no rights against PEH with respect thereto, except such rights as may exist under applicable patent laws.

Independent Contractors

PEH and Purchaser are independent contractors and neither has the authority to assume or to create any obligation on behalf of or in the name of the other.

Set Off

PEH shall be entitled to set off any amount or apply any sum due from Purchaser to PEH or any other affiliated company of PEH.

Force Majeure

PEH shall not be responsible or liable for any delays or failures in manufacture or delivery due to any cause or condition beyond the reasonable control of PEH. PEH shall not be responsible or liable for any delays or failures to deliver or to perform its contractual responsibilities if due to causes beyond its reasonable control or the reasonable control of its suppliers, or due to acts of God, acts of civil or military authority, judicial action, fires, strikes, floods, wars, transportation delays, or inability due to causes beyond its reasonable control to obtain necessary labor, materials or manufacturing facilities. In the event of such a condition or circumstance, PEH shall have the right, at its option, to cancel any purchase orders or any part thereof without any resulting liability.

Applicable Law

The terms and conditions expressed herein shall be construed and its performance governed by the internal laws (as opposed to conflicts of law provisions) of the State of Colorado.

Headings

All headings or captions used herein are for convenience of reference only and shall not limit or define these terms and conditions.

Interpretation

Whenever the term "include", "includes", or "including" is used in this document or any document referenced in this document, it shall mean "including, without limitation," (whether or not such language is specifically set forth) and shall not be deemed to limit the range of possibilities to those items specifically enumerated. The words "hereof", "herein" and "hereunder" and words of similar import refer to this document and any document referenced in this document as a whole and not to any particular provision. Terms defined in the singular have a comparable meaning when used in the plural and vice versa.

NOTES:



info@enfusionenergy.com

(877) 230 7501

For further information scan this code:



US Patents:

PATENT NO. 10,931,220

PATENT NO. 10,840,831

PATENT NO. 10,560,033

PATENT NO. 11,171,486

International Patents:

PATENT NO. (EP) 3,362,867

PATENT NO. (AU) 2016338999

PATENT NO. (CN) 108431719

MADE IN THE
USA