



Blender 2500 Manual

# ZENFUSION™

B L E N D E R

Revision 5.0



## Before You Get Started

### IMPORTANT:

This manual contains important instructions that should be followed during installation, operation and maintenance of the Blender 2500 controller. Carefully read and follow all safety instructions in this manual. Make sure that safety labels are always in good condition and replace missing or damaged safety labels.



Before performing any service or maintenance inside the controller or when connecting or disconnecting any wires, **DISCONNECT the power** and **WAIT 90 seconds** to allow the capacitor bank inside the controller to discharge to a level below 50V.

**DO NOT** turn on the power to the controller before terminating all wiring connections and closing the cover door.

**DO NOT** connect power wiring to the controller before mounting the box.

**DO NOT** service the device if your hands are wet or damp. Always make sure hands are dry before working on the controller.

**DO NOT** modify equipment inside the controller.

**DO NOT** remove any parts of the controller unless instructed by this manual.

The controller should be **installed and inspected by technically qualified personnel** and if the controller is not installed in compliance with national and local electrical codes and ENFusion™ recommendations, the controller can be damaged and fail to operate.

**FOLLOW** instructions in this manual and labels inside the controller for proper and successful installation.

# TABLE OF CONTENTS

- INSTALLATION ..... 1**
- Task 1: Mount the Blender 2500 ..... 2**
  - Step One: Decide Best Location..... 2**
    - Important Pre-Installation Warnings..... 2
    - Blender 2500 Requirements for Safe Installation ..... 2
    - Blender 2500 Mounting Clearances..... 3
    - Blender 2500 Dimensions..... 4
  - Step Two: Mount the Blender 2500 ..... 4**
    - Blender 2500 Unit Mounting Instructions..... 4
- Task 2: Wire the Blender 2500 ..... 7**
  - Step One: Review Wiring Requirements and Warnings ..... 7**
    - Installation Requirements ..... 7
    - Wiring Warnings..... 7
  - Step Two: Review System Wiring Diagrams..... 7**
    - Review Overview Diagram of Blender 2500 Showing Five Wire Glands ... 7
    - Review Closeup of Internal Wiring Features..... 8
    - Review Blender 2500 Circuit Board Diagram. .... 9
    - Review Blender 2500 System Wiring Diagram ..... 11
    - Wiring For Single-Phase Motor Loads.. .... 12
  - Step Three: Wire to AC (Grid) and DC (Solar) Sources ..... 12**
    - Wire to AC and DC Sources as Per Wiring Diagram ..... 12
    - Tighten The DIN Rail Terminals ..... 13
  - Step Four: Set Blender 2500 DIP Switch Settings ..... 13**
    - Set DIP Switches 1, 2, or 3 to Match Your Motor..... 14
    - Set DIP Switches 4 and 5 to Match Minimum Operating Motor Frequency .. 14
    - Set DIP Switches 6 and 7 for Overcurrent Protection ..... 15
    - Set DIP Switch 8 (If DIP Switch 2 Is Set for Single-Phase Operation) ... 15
    - Set DIP Switch 9 for Flow Switch Dry Well Protection ..... 16
    - Set DIP Switch 10 for Flow Switch Time Delay..... 16
    - Set DIP Switch 11 for Automatic Dry Well Protection..... 17
    - Install Cover Door and Tighten It ..... 17
  - Step Five: (Optional) Set Blender 2500 Sensor Setting ..... 17**
    - Remote Turn On/Off With Digital Input or Standard Float Switch..... 17
    - Blender 2500 Can Incorporate Two External Analog Sensors ..... 18
- Task 3: Complete Installation Notes ..... 19**
  - After Installation, Complete Installation Notes..... 19
  - Tech Support Hotline: 877 230 7501 ..... 19
  - Keep This Manual With Your Blender 2500 Unit ..... 19
- CONFIGURATION ..... 20**
- Task 4: Configure the Blender 2500 ..... 21**
  - Step One: Size the Solar Panel Array to Motor Load Power Requirements  
and AC Source Voltage..... 21**

<b>OPERATION</b> .....	<b>22</b>
<b>Task 5: Initial Blender 2500 Startup</b> .....	<b>23</b>
<b>Step One:</b> Start Blender 2500 for the First Time .....	23
<b>Step Two:</b> Understand Meaning of Blender 2500's LED Lights.....	23
Motor Is Properly Connected.....	23
Blender 2500 Overload Protection.....	24
Automatic Blending Mode .....	24
Solar Only Mode .....	24
<b>Step Three:</b> Manually Shut Down Blender 2500 Operation.....	25
Understanding Automatic Shutdown of Blender 2500.....	25
Automatic Shutdown With Tank or Well Float Switch.....	25
Automatic Shutoff Due to Temperature .....	25
Power Deration Mode .....	25
Manually Shut Off Power Blending.....	26
<b>MAINTENANCE OF BLENDER 2500</b> .....	<b>27</b>
<b>Task 6: Perform Recommended Maintenance</b> .....	<b>28</b>
Inspect Every Three Months.....	28
Maintain Optimal Operational Conditions .....	28
Keep Clear of External Obstructions .....	28
Don't Operate in Freezing Conditions .....	28
Check External Sensors Every 3 Months.....	28
Keep the Unit Out of Direct Sunlight .....	28
Troubleshoot LED Indicator Lights .....	28
<b>Appendix A: How Blender Works</b> .....	<b>30</b>
Understand How to Maximize Solar Energy/Utility Energy.....	31
<b>Appendix B: Product Description, Product Specifications</b> .....	<b>32</b>
Product Description.....	32
Product Specifications.....	33
<b>Appendix C: Calculate Maximum Cable Lengths for Different Motor Load Currents</b> .....	<b>34</b>
<b>Appendix D: Optional Blender 2500 Module</b> .....	<b>35</b>
About the Blender 2500 GFCI (Ground Fault Circuit Interrupter) Module ..	35
<b>Terms and Conditions</b> .....	<b>37</b>

 **NOTICE**

*This manual is intended to be used as an installation and operation guide. The information in this document is subject to change without notice. No part of this document may be reproduced in any form or by any means without the express written permission of ENFusion™.*

# INSTALLATION

# Task 1: Mount the Blender 2500

## Step One: Decide Best Location

### Important Pre-Installation Warnings

**////// ⚠ WARNING ////**

*Do not ground the positive or negative leads of the PV modules! Only ground the mounting frames of the PV modules. Never run the Blender controller when the AC pump is not connected! It might cause damage to the controller.*

*If an installed three-phase pump does not start pumping water, switch the positions of any two of the three motor wires. It will change the direction of rotation and it should start pumping water!*

- Contact your ENFusion™ Supplier/Dealer for any service or warranty claims at [info@enfusionenergy.com](mailto:info@enfusionenergy.com).
- National Electric Code (NEC) takes precedence over suggestions in this manual.

We strongly recommend that the installation data be recorded into the "Installation Notes" (See Figure 22: Installation Notes) and that you keep the manual stored near the unit.

### **Blender 2500 Requirements for Safe Installation**

The Blender 2500 must be installed in a shaded location away from any source of heat and moisture and in an area free of vegetation. Measures must also be made to protect the unit from damage by unauthorized persons, large animals, overgrowth, flooding or other harm.

The Blender 2500 should not be exposed to direct sunlight. The ideal location for the unit is underneath the solar panels, as our illustrations show.

## Blender 2500 Mounting Clearances

- The Blender 2500 should be mounted at least 24 inches (60cm) above the ground when possible.
- A minimum of 10 inches (25cm) of clearance above the Blender 2500 is required for internal access.
- There must not be an obstruction of air flow to the heatsink.

A typical installation on an array structure is shown in Figure 1: Blender 2500 Mounting Clearances.

*Figure 1: Blender 2500 Mounting Clearances*

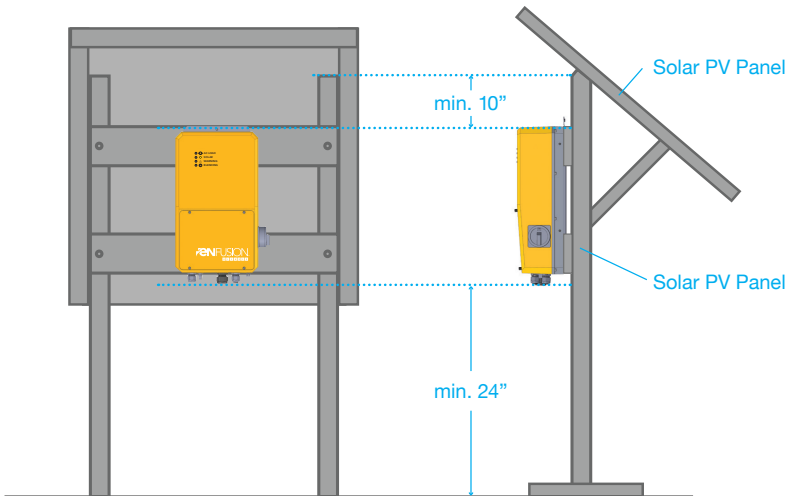

## Blender 2500 Dimensions

Dimensions of the Blender 2500 and back panel are shown in Figure 2: Blender 2500 Dimensions with additional details on how to mount the unit in Figures 3: Back View of Blender 2500 Mounting Bracket and Figure 4: Blender 2500 Unit Mounting Instructions.

**Figure 2: Blender 2500 Dimensions**

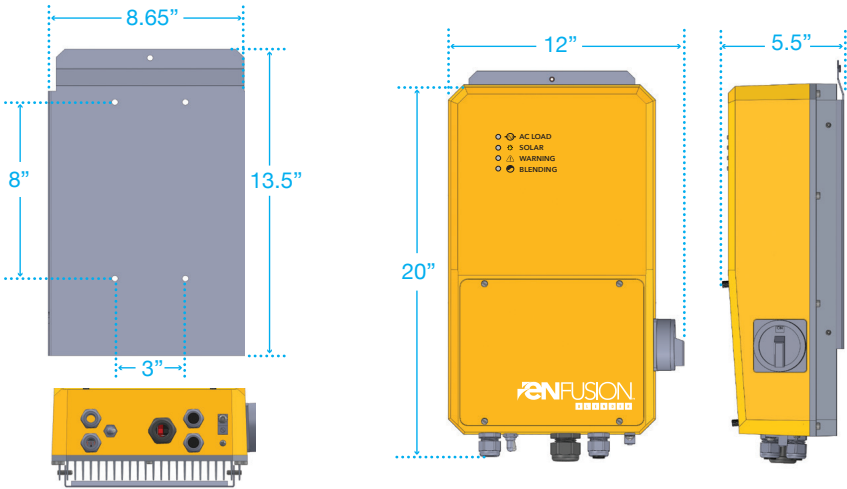

## Step Two: Mount the Blender 2500

### Blender 2500 Unit Mounting Instructions

Blender 2500 controller should be mounted on a wall or other vertical surface using the back bracket (See Figure 3: Back View of Blender 2500 Mounting Bracket).

On the back side of the unit there are two set screws (not included) used to hang the unit on the back bracket. More detailed mounting instructions are shown in Figure 4: Blender 2500 Unit Mounting Instructions.

Figure 3: Back View of Blender 2500 Mounting Bracket

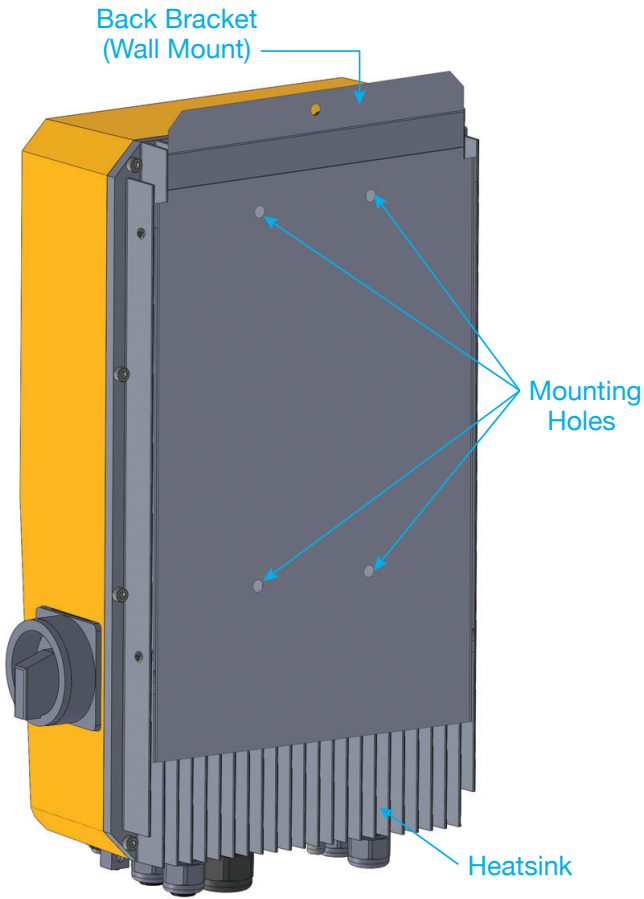

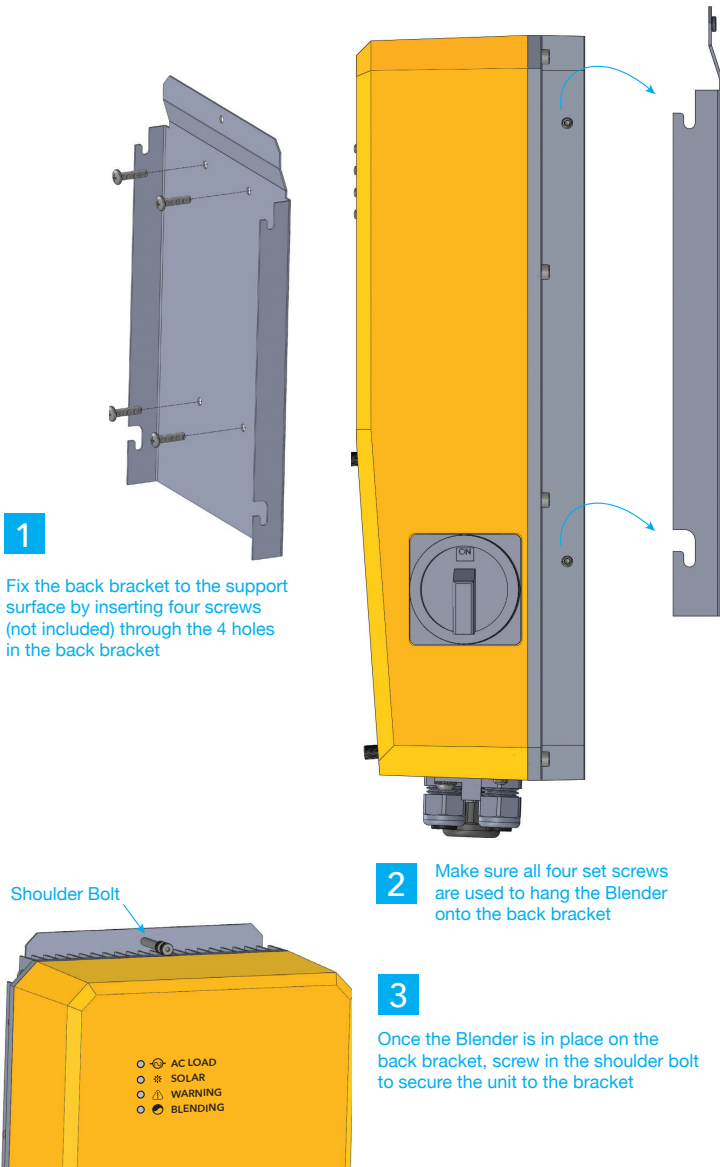
**Figure 4: Blender 2500 Unit Mounting Instructions**

## Task 2: Wire the Blender 2500

### Step One: Review Wiring Requirements and Warnings

#### Installation Requirements:

All electrical installations must be carried out in accordance with local standards and the National Electrical Code (NEC).

Conductor rated current, temperatures, operating conditions and its power loss must be made in accordance with local standards and the National Electrical Code (NEC).

#### Wiring Warnings



*Do not ground the positive or negative leads of the PV modules! Only ground the mounting frames of the PV modules. Never run the Blender controller when the AC pump is not connected! It might cause damage to the controller.*

*If an installed three-phase pump does not start pumping water, switch the positions of any two of the three motor wires. It will change the direction of rotation and it should start pumping water!*

### Step Two: Review System Wiring Diagrams

#### Review Overview Diagram of Blender 2500 Showing Five Wire Glands

The unit has five wire glands:

- One large gland for a motor cable (middle)
- Two glands for solar PV and AC source cables (right side)
- Two glands for data cables (left side) and for a float switch sensor or other optional sensor

There is direct access to the power and signal terminals on the DIN rail once the enclosure door is removed (See Figure 5: Overview Diagram of Blender 2500 Showing Five Wire Glands).

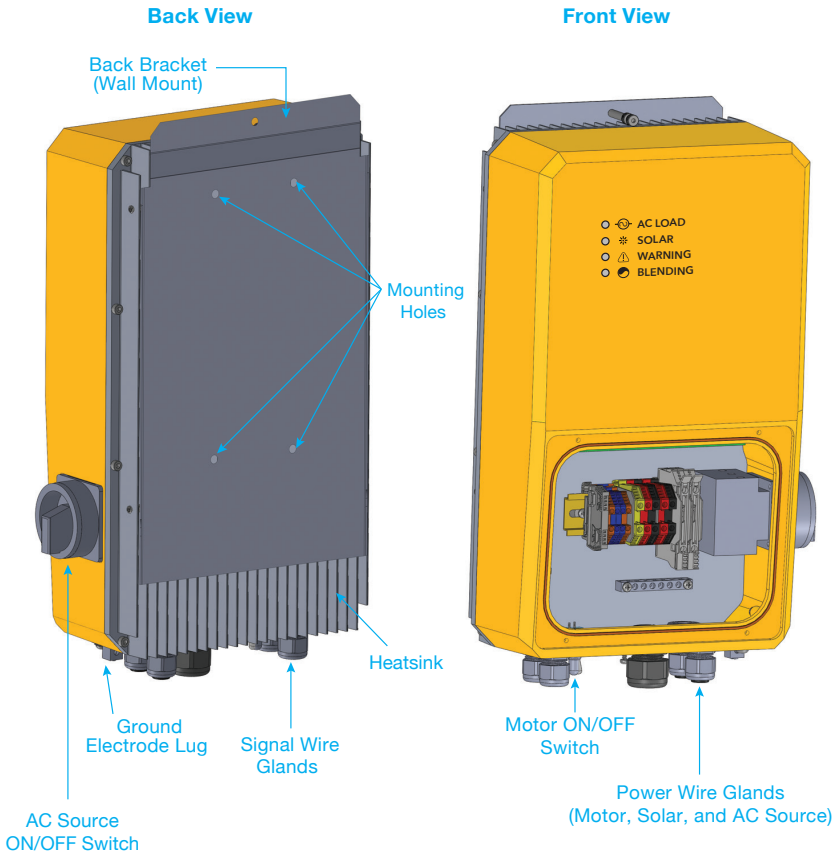
**Figure 5: Overview Diagram of Blender 2500 Showing Five Wire Glands**

### Review Closeup of Internal Wiring Features

Once the door of the enclosure is removed, there is access to the input terminal blocks (DIN rail mounts) on the right. See Figure 6: Closeup of Internal Wiring Features.

- Below the DIN rail is a grounding block for connecting the equipment ground.
- The installer should only use the DIN rail terminals for connecting all external wires to the Blender 2500 unit.

On the bottom left, just next to the external sensors gland, there is a motor ON/OFF switch that controls the Blender 2500's operation of the motor.

**Figure 6: Closeup of Internal Wiring Features**

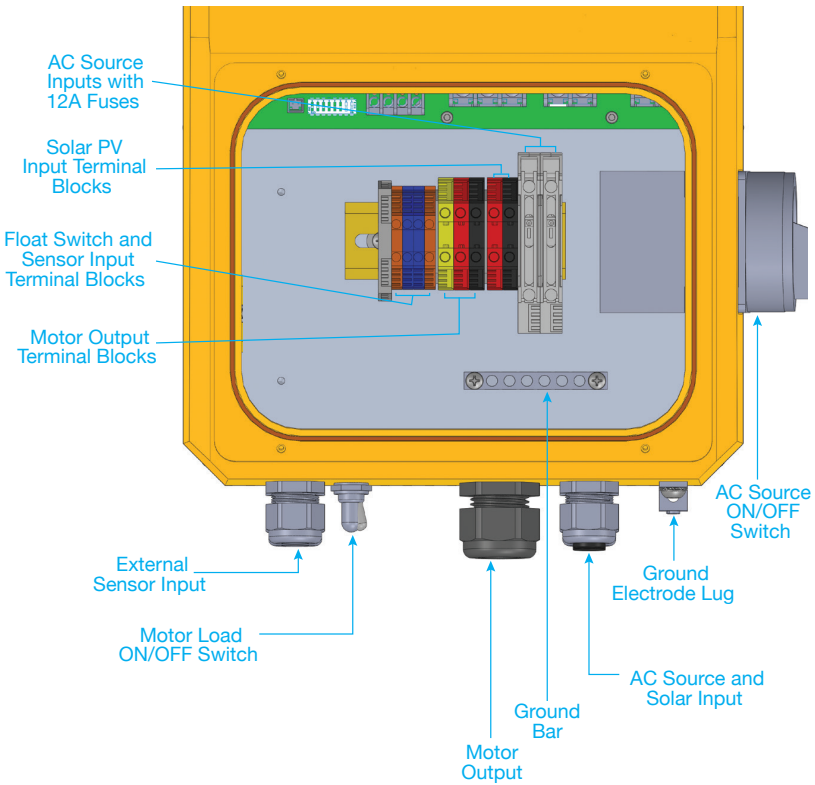

### **Review Blender 2500 Circuit Board Diagram**

The features of a Blender 2500's printed circuit board are shown in Figure 7: Blender 2500 Circuit Board Diagram.

The installer needs access to these features when configuring the Blender 2500's DIP switches to match the AC motor load specifications (described in greater detail in Step Four: Set Blender 2500 DIP Switch Settings).

**Figure 7: Blender 2500 Circuit Board Diagram**

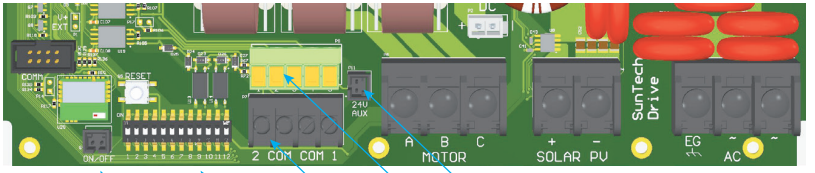

Terminal for Motor ON/OFF Switch

24V for GFCI

Analog Sensor Inputs (P9)

Float Switches

**DIP Switches**

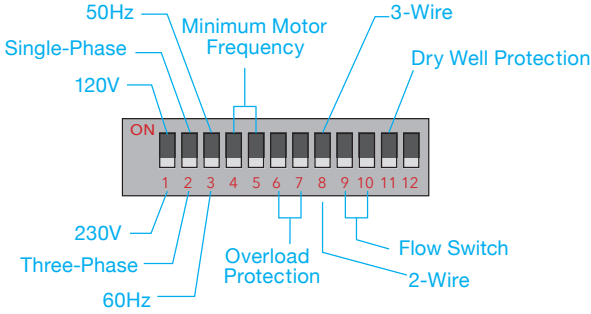

**WARNING**

*Do not modify DIP switch settings until power has been turned off and after 90 seconds have passed for internal voltages to discharge below voltage of 50V! Power must be removed for DIP switch settings to take effect.*

## Review Blender 2500 System Wiring Diagram

The Blender 2500 System Wiring Diagram is a top level wiring diagram illustrating how the Blender takes energy from both solar panels and the grid.

**Figure 8: Blender 2500 System Wiring Diagram**

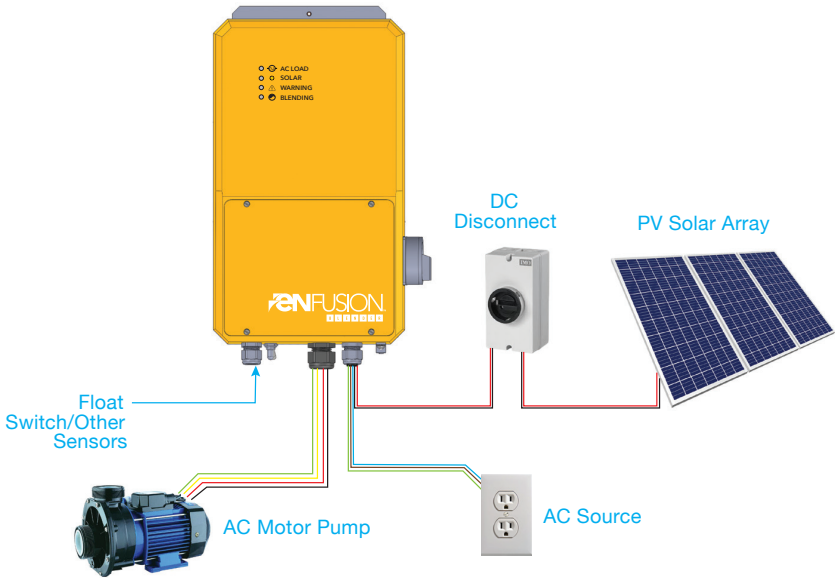

### **WARNING**

**Do not ground the positive or negative leads of the PV modules!  
Only ground the mounting frames of the PV modules.  
Never run the Blender controller when the AC pump is not connected!  
It might cause damage to the controller.  
If an installed three-phase pump does not start pumping water, switch  
the positions of any two of the three motor wires. It will change the  
of rotation and it should start pumping water!**

## Wiring for Single-Phase Motor Loads

- Single-phase motor loads should be wired as shown in Figure 9: Table of Wiring for Single-Phase Motor Loads.
- Single-phase 2-wire motors should be connected to phase A and C, while 3-wire motors should be wired so that common lead is wired to phase A, starting winding to phase B and main winding to phase C. Use DIP Switch 8 for proper single-phase motor selection.

**Figure 9: Table of Wiring for Single-Phase Motor Loads**

<b>IMPORTANT:</b>	
Single-phase 2-wire motor pumps:	Connect to A and C motor terminals of Blender
Single-phase 3-wire motor pumps:	Ph_A: <b>YELLOW</b> wire - common motor lead Ph_B: <b>RED</b> wire - start motor lead Ph_C: <b>BLACK</b> wire - main motor lead

## Step Three: Wire to AC (Grid) and DC (Solar) Sources

### Wire to AC and DC Sources as Per Wiring Diagram

Once the Blender 2500 is installed in a shaded location as shown in Figure 1: Blender 2500 Mounting Clearances, it should be wired to AC (grid) and DC (solar) sources with voltage and current levels defined in the Product Specifications found on page 33.

Maximum cable lengths for 115 and 230V for different load currents are shown in Figure 30: Maximum Input Cable Lengths in Feet (Based On 3% Voltage Drop).

**Figure 10: Internal Wiring Diagram to AC and DC Sources**

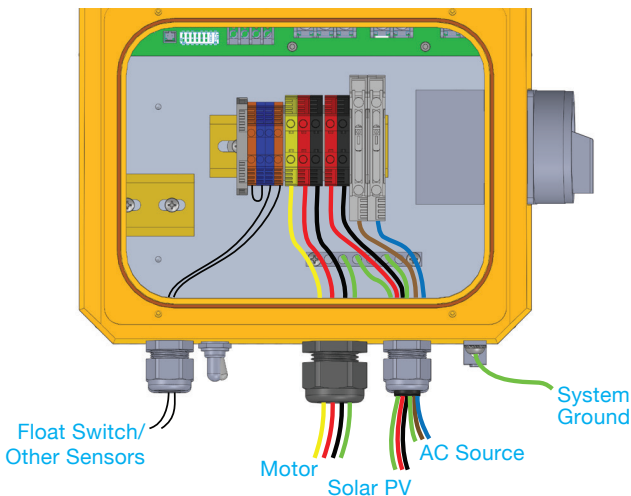

### Tighten the DIN Rail Terminals

Once the system is wired per Figure 10: Internal Wiring Diagram to AC and DC Sources, the power conductors wired to the DIN rail terminals inside the Blender 2500 should be tightened with torque values of:

- Solar PV and motor load conductors: 11 lb-in.
- AC source conductors: 8 lb-in.

The cable glands (cord grips) on the bottom of the enclosure should be used as:

- 1/2 inch cord grips should only be used with a cord that is 0.280-0.455 inch outer diameter.
- 3/4 inch cord grips should only be used with a cord that is 0.455-0.705 inch outer diameter.

### Step Four: Set Blender 2500 DIP Switch Settings

Configuring DIP switch settings is crucial to the Blender 2500 to recognize the motor (load) and any other parameters or constraints in the application. NEVER skip DIP switch configuration. It will always apply in one form or another to your application.

Note that the DIP switch board shows 12 slots. Only 11 slots are currently in use. (See Figures 11 and 12 regarding DIP Switches.)

**Figure 11: Location of DIP Switches on Circuit Board**

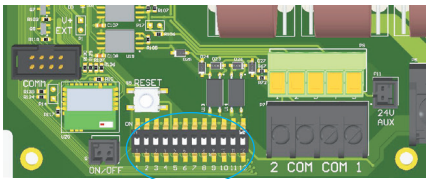

**DIP Switches**

**Figure 12: Closeup of DIP Switches**

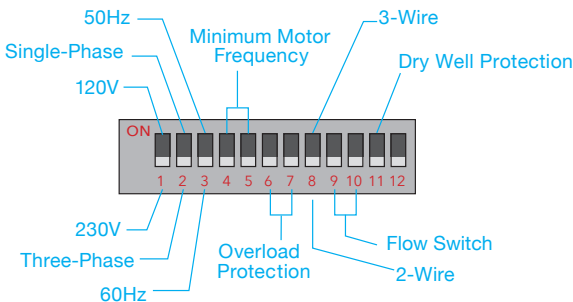

### Set DIP Switches 1, 2, or 3 to Match Your Motor

The Blender 2500 controller can operate most AC motors up to the power limits of the controller: single or three-phase; 50 or 60Hz; 120V or 230V. In order for the Blender 2500 to match the motor specifications, the first three DIP switches on the left are used for motor selection:

#### DIP Switch 1 – 120/230V:

- If switched ON (up – as in Figure 13: Set Dip Switches 1, 2, 3 to Match Your Motor) the unit is configured for 120V pump operation.
- If switched OFF (down) the unit is configured for 230V.

#### DIP Switch 2 – 1/3 phase:

- If switched ON (up – as in Figure 13: Set Dip Switches 1, 2, 3 to Match Your Motor) the unit is configured for single-phase motor operation.
- If switched OFF (down) the unit is configured for three-phase motor operation.

#### DIP Switch 3 – 50/60Hz:

- If switched ON (up – as in Figure 13: Set Dip Switches 1, 2, 3 to Match Your Motor) the unit is configured for 50Hz motors.
- If switched OFF (down) the unit is configured for 60Hz motors.

**Figure 13: Set Dip Switches 1, 2, 3 to Match Your Motor**

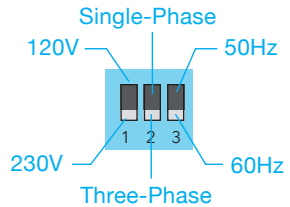

### Set DIP Switches 4 and 5 to Match Minimum Operating Motor Frequency

#### DIP Switches 4 and 5 - Minimum Operating Motor Frequency:

- It is possible to set up a minimum operating motor frequency. This is important when operating in Solar Only mode and when there is not enough solar power available to pump water due to high dynamic head.
- In order to prevent “dead heading,” it is possible to set the minimum frequency in the range of 30 to 50Hz, using a combination of DIP switches 4 and 5 as shown in Figure 14: DIP Switches 4 and 5 to Match Minimum Operating Motor Frequency.

**Figure 14: DIP Switches 4 and 5 to Match Minimum Operating Motor Frequency**



DIP Switches	Minimum Motor Frequency
	30Hz
	40Hz
	45Hz
	50Hz

- NOTE: The Blender 2500’s default minimum Hz setting is 30Hz.

## Set DIP Switches 6 and 7 for Overcurrent Protection

### DIP Switches 6 and 7 - Overcurrent Protection:

- The Blender 2500 can set overcurrent protection based on the motor pump and controller combination being used.
- Figure 15: Set DIP Switches 6 and 7 for Overcurrent Protection shows how to set up overcurrent protection using DIP switches 6 and 7.
- The default value of RMS current (when both switches are OFF) is 10A for single-phase and 8A for three-phase.
- DIP switches 6 and 7 are to be used to match or exceed the motor nameplate's SFAMPS in order to protect from overcurrent.
- For example, if a single-phase motor has SFAMPS: 7.4A, then DIP switches 6 and 7 have to be set for 8A, as this is the next highest protection current for this motor.
- Configuring Overcurrent Protection also configures automatic Dry Well Protection.**
- The Blender 2500 monitors motor amperage or dry well protection and no other dry well sensor input is needed unless desired.

**Figure 15: Set DIP Switches 6 and 7 for Overcurrent Protection**



DIP Switches	Overcurrent Single-Phase	Overcurrent Three-Phase
	10A	8A
	8A	6.5A
	6.5A	5A
	5A	4A

### Set DIP Switch 8 (If DIP Switch 2 Is Set for Single-Phase Operation)

#### DIP Switch 8 2-wire/3-wire: Single-Phase

- Used for setting up the proper mode for single-phase operation
- This is relevant only when DIP switch 2 is set for single-phase operation
- The default setting is for single-phase 2-wire motors, when DIP switch 8 is in the OFF [down – as in Figure 16: DIP Switch 8 (If DIP Switch 2 Is Set for Single-Phase Operation)] position.
- For 3-wire single-phase motors, DIP switch 8 should be in the ON (up) position

**Figure 16: DIP Switch 8 (If DIP Switch 2 Is Set for Single-Phase Operation)**

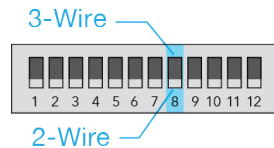

## Set DIP Switch 9 for Flow Switch Dry Well Protection

### DIP Switch 9 Flow Switch Dry Well Protection:

- When combined with an additional flow switch, the Blender 2500 offers dry well protection by setting DIP switch 9 to the ON (up – see Figure 17: DIP Switch 9 for Flow Switch Dry Well Protection) position.
- The Flow Switch needs to be installed in-line with the pipe (ask your dealer for Flow Switch availability).
- The principle of operation is very simple. As soon as the pump starts and water begins flowing through the pipe, the magnetic Flow Switch turns ON, which indicates to the Blender 2500 that there is water in the well.
- If there is no water, the Flow Switch will indicate a dry well condition, and the Blender 2500 will turn the pump off.
- There is a time delay from the start of the pump for the Flow Switch signal to activate, which allows time for flow from deep wells. See DIP Switch 10 for time delay settings.

**Figure 17: DIP Switch 9 for Flow Switch Dry Well Protection**

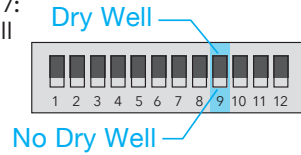

## Set DIP Switch 10 for Flow Switch Time Delay

### DIP Switch 10 Time Delay - Flow Switch Time Delay:

- Used to define the time delay for Flow Switch sensing.
- When DIP switch 10 is in the OFF (down – as in Figure 18: DIP Switch 10 for Flow Switch Time Delay) position (default) the delay time is 15 seconds.
- When it is in the ON (up) position, the delay time is 30 seconds.
- A 15 second setting is used for more shallow wells (less than 300ft), while 30 seconds is used for deeper wells (deeper than 300ft).

**Figure 18: DIP Switch 10 for Flow Switch Time Delay**

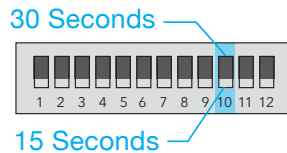

## Set DIP Switch 11 for Automatic Dry Well Protection

### DIP Switch 11- Automatic Dry Well Protection:

- See Figure 19: DIP Switch 11 for Automatic Dry Well Protection. The Blender 2500 monitors motor amperage for dry well protection.
- No other dry well sensor input is needed unless desired.
- The default setting is dry well protection ON (down).
- If switched OFF (up), the protection is disabled.
- Turn dry well protection off for compressors, fans, and above-ground pumps.

Figure 19: DIP Switch 11 for Automatic Dry Well Protection

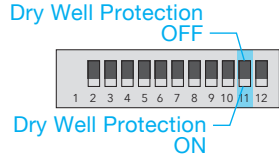

### Install Cover Door and Tighten It

When all conductors are wired into the controller the cover (door) should be put on and tightened using the cover screws to 2-3 in-lb or equivalent.

## Step Five: (Optional) Set Blender 2500 Sensor Settings

### Remote Turn On/Off With Digital Input or Standard Float Switch

The Blender 2500 controller can be remotely turned ON or OFF by using a digital input or by using a standard float switch. There is a float switch terminal block where digital signal wires are connected.

- If Digital Inputs 1 and COM experience a short circuit then the Blender 2500 automatically turns off.
- Similarly, if Digital Input 2 and COM experience an open circuit then the Blender 2500 automatically turns off.
- There are numerous remote sensors that can be used: float switch, pressure switch, flow switch, water level sensor, dry run protection, etc. Ask your dealer about configuring sensors and switches for your application.

Figure 20: Example of "Water Tank Full" and "Well Empty"

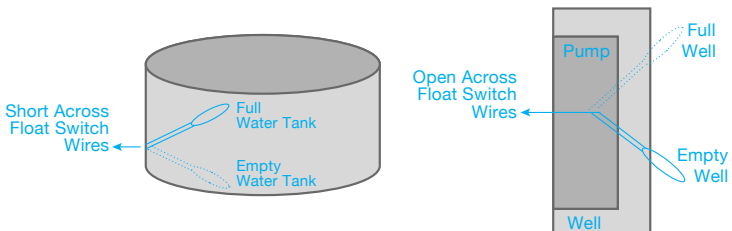

A typical example of how tank and well switch signals can be used with a digital input port is shown in Figure 20: Example of “Water Tank Full” and “Well Empty”.

- For a tank application, if the active wire is connected to Position 1 and the return wire (usually black) is connected to Position COM, then the Blender 2500 will stop the pump when the tank gets full because terminals 1 and COM will be “shorted” (active short). This turns off the Blender 2500.
- For a well application, if the active wire is connected to Position 2 and the return wire (usually black) is connected to Position COM, then the Blender 2500 will stop the pump when the well runs out of water because terminals 2 and COM will be “open” (active open). This turns off the Blender 2500.

### **Blender 2500 Can Incorporate Two External Analog Sensors**

The Blender 2500 can incorporate **two external analog sensors**.

- Analog sensors should be fed through the left cable glands and terminated to connector P9 on the printed circuit board, as shown in Figure 7: Blender 2500 Circuit Board Diagram.
- The analog sensor inputs are designed for 4-20mA input for common industrial sensors.

A table with pinout details is shown in Figure 21: Analog Sensor Pins for Analog Sensors, which includes 24V power on Pin 5, eliminating the need for an external power supply.

**Figure 21: Analog Sensor Pins for Analog Sensors**

<b>Pin Number</b>	<b>Functionality</b>
Pin 1	Analog 1
Pin 2	24V
Pin 3	GND
Pin 4	Analog 2
Pin 5	24V

## **Task 3: Complete Installation Notes**

### **After Installation, Complete Installation Notes**

We strongly recommend that the you take an extra bit of time to fill out the installation notes (See Figure 22: Installation Notes) with valid data once installation is complete.

When you call our technical support, we will ask you for this information. If you have this installation data available, you will have a faster and more accurate troubleshooting process. It's hard to keep track of this information once installation is complete.

*Figure 22: Installation Notes*

Date Installed: \_\_\_\_\_

Serial No. (Spec Label): \_\_\_\_\_

Installer: \_\_\_\_\_

Phone: \_\_\_\_\_

Location of Installation: \_\_\_\_\_

Pump Manufacturer / Model No.: \_\_\_\_\_

Motor: HP, V, ph, SF Amps: \_\_\_\_\_

Well Depth: (m/ft) \_\_\_\_\_

Flow Rate: (lpd/gpd) \_\_\_\_\_

PV Panel Manufacturer / Model No.: \_\_\_\_\_

No. of Solar PV Panels in Series: \_\_\_\_\_

**Tech Support Hotline: 877 230 7501**

### **Keep This Manual With Your Blender 2500 Unit**

We recommend that you keep the manual accessible and located close to the unit. If you have a protected location, keep the manual with the unit. If not, keep it easily accessible in the office.

# CONFIGURATION

## **Task 4: Configure the Blender 2500**

### **Step One: Size the Solar Panel Array to Motor Load Power Requirements and AC Source Voltage**

The Blender 2500 can be powered only from a single-phase AC source, 115V or 230V.

- However, the Blender 2500 can power both single and three-phase motors.
- It is also possible to run single/three-phase 230V motors when the Blender 2500 is powered from a 115V AC source, as long as the AC power does not exceed 12A of input.

When sizing the solar panel array for the Blender 2500, it is necessary to know the motor load power requirements and the AC source voltage.

The general recommendation is to size the solar PV system capacity to at least match the motor power requirements.

- To do so, it is important to know the motor power when sizing the solar system.
- It is further recommended to oversize the solar system, especially in areas of high electricity rates, in order to maximize solar energy and offset the AC source during several hours of the day.
- Contact your dealer for solar sizing for your specific motor.

## OPERATION

## Task 5: Initial Blender 2500 Startup

### Step One: Start Blender 2500 for the First Time

Once the Blender 2500 controller is wired to the solar source, a motor load and the DIP switches settings are configured to match the motor specification, then the Blender 2500 is ready for operation.

#### **When starting the Blender 2500 for the first time:**

1. Make sure that the ON/OFF toggle switch is in the OFF position.
2. Turn the AC switch (on the right side of the Blender 2500) to the ON position to provide AC power to the Blender 2500.
3. Power up the Blender 2500 from solar PV (if available) by switching the solar DC disconnect to the ON position.
4. Once both solar PV and AC source power are provided to the Blender 2500 turn the bottom toggle switch to the ON position to start the motor load.

The Blender 2500 will check its motor connections using builtin open and short circuit protections. If one of the motor leads is not connected, or if there is a short in the motor connections, the Blender 2500 will show a warning message using indication LEDs (See Figure 26: Chart Summarizing All Indicator Light Combinations, and Figure 27: Chart Explaining Meaning of Indicator Light Combinations).

If there is any issue with the unit different combinations of LED's will light up and/or flash to indicate the malfunction. (See Figure 26: Chart Summarizing All Indicator Light Combinations and Figure 27: Chart Explaining Meaning of Indicator Light Combinations).

**Never run the Blender 2500 controller when the AC pump is not connected! It might cause damage to the controller.**

### Step Two: Understand Meaning of Blender's LED Lights

Four LEDs are used to indicate the Blender 2500 controller's operation (See Figure 23: LED 1 - AC Load Is On, and Figure 24: LED 2 - Solar Is On).

#### **Motor Is Properly Connected**

*Figure 23: LED 1 - AC Load Is On*

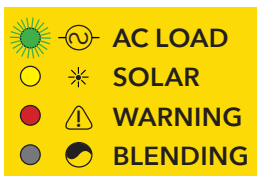

If the motor is properly connected, the Blender 2500 will move to the startup procedure. The green AC LOAD LED (See Figure 23: LED 1 - AC Load Is On) will have a solid green light and the motor will start running. The Blender 2500 immediately performs MPPT operation over the solar PV input to offset AC source power.

### Blender 2500 Overload Protection

The Blender 2500 has built-in overload protection. If a connected motor has a power level higher than the Blender 2500 can handle:

- It first slows down and tries to run the motor at a lower power level.
- If the motor power continues to be outside the power range of the Blender 2500 it will shut off the motor.

### Automatic Blending Mode

If the AC switch on the right side is ON, then the Blender 2500 is automatically in Blending Mode, using as much power as is available from the solar PV panels while automatically supplementing on an as-needed basis from the AC power source.

### Solar Only Mode

If the AC switch is in the OFF position, then the Blender 2500 operates in Solar Only Mode, and it will not draw any power from the grid but will balance the power from solar with motor power by varying the motor frequency. If there is not enough solar power then the unit's SOLAR LED light will blink yellow, as shown in Figure 24: LED 2 - Solar Is On.

*Figure 24: LED 2 - Solar Is On*

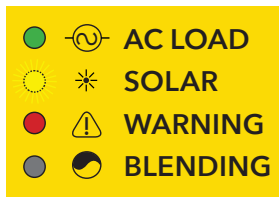

### **Step Three: Manually Shut Down Blender 2500 Operation**

To stop the Blender 2500's operation the ON/OFF toggle switch on the bottom of the unit should be used. Once in the OFF position the Blender 2500 will automatically stop the motor's operation.

### **Understanding Automatic Shutdown of Blender 2500**

#### **Automatic Shutdown with Tank or Well Float Switch**

If a tank or well float switch is used (See Figure 20: Example of "Water Tank Full" and "Well Empty") when the tank becomes full or the well becomes empty, the Blender 2500 will stop its operation and the WARNING LED will blink red.

#### **Automatic Shutoff Due to Temperature**

The WARNING LED will be solid red if the temperature of the Blender 2500 rises above 80°C at which point the Blender 2500 will stop operating and wait until the temperature drops. This can happen if the unit is exposed to direct sunlight, which should be avoided.

#### **Power Deration Mode**

- If the Blender 2500 gets too hot during its normal operation it will switch to Power Deration mode, limiting the maximum power that is transferred to the motor load.
- During that time, the AC LOAD LED will be solid green and the WARNING LED will be solid red.
- If the unit cools down to a regular operating temperature it will automatically continue operation without the thermal deration.
- If the temperature of the Blender 2500 continues to increase it will eventually stop operating, at which point the WARNING LED will be solid red.

## Manually Shut Off Power Blending

Figure 25: Manually Shut Off Power Blending

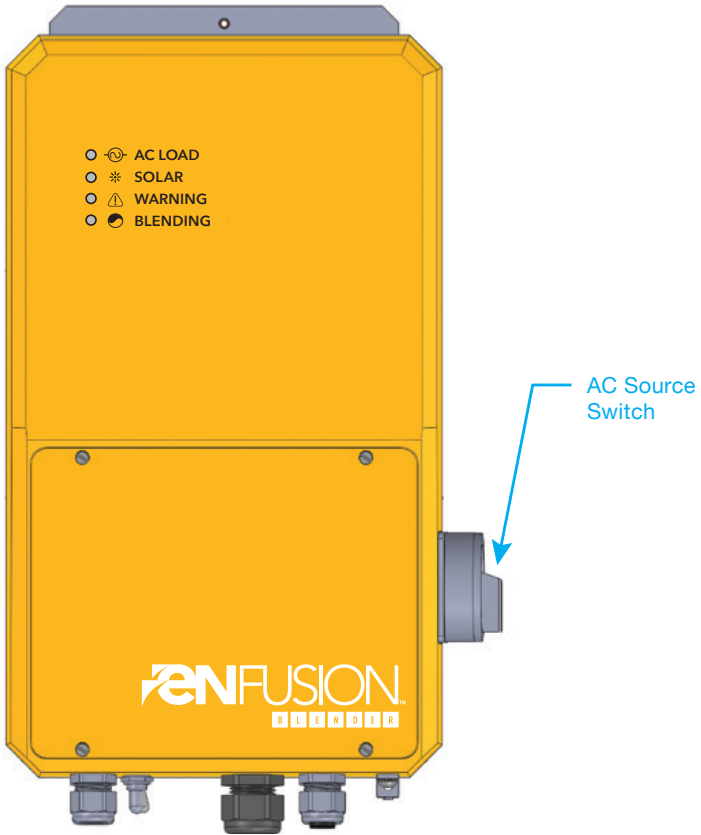

If necessary, the power blending capability can be turned OFF using the AC Source switch on the right-hand side of the Blender 2500.

## **MAINTENANCE**

## Task 6: Perform Recommended Maintenance

### Inspect Every Three Months

The Blender 2500 unit is designed to operate autonomously. However, we suggest regular inspections every 3 months.

### Maintain Optimal Operational Conditions

#### **Keep Clear of External Obstructions.**

- If there are any external obstructions that prevent proper cooling of the heatsink area, please remove them to make sure nothing blocks the air flow from the bottom of the device.

#### **Don't Operate in Freezing Conditions**

- If the Blender 2500 operates in an area where the pump experiences freezing temperatures make sure to turn the device OFF so it does not try to run the water pump in icy conditions. This may lead to deadheading on the pump.

#### **Check External Sensors Every 3 Months**

- Check external sensors every 3 months: float switch, pressure switch, etc.

#### **Keep the Unit Out of Direct Sunlight**

- The Blender 2500 should be installed and kept in a shaded location.

### Troubleshoot LED Indicator Lights

If there is any issue with the unit, different combinations of LED's will light up and/or flash to indicate the malfunction. The following two charts explain the various Indicator Light Combinations (See Figure 26: Chart Summarizing All Indicator Light Combinations, and Figure 27: Chart Explaining Meaning of Indicator Light Combinations).

*Figure 26: Chart Summarizing All LED Indicator Light Combinations*

AC LOAD	SOLAR	WARNING	MODE
ON	ON	ON	- Unit is OFF
FLASHING	OFF	OFF	- Startup
ON	OFF	OFF	- Running
OFF	FLASHING	OFF	- Standby
OFF	OFF	FLASHING	- Float switch
OFF	OFF	ON	- Over temperature
ON	OFF	ON	- Power deration
FLASHING	OFF	FLASHING	- Over current
OFF	FLASHING	FLASHING	- Short/Open circuit
FLASHING	FLASHING	FLASHING	- Dry well protection

**Figure 27: Chart Explaining Meaning of LED Indicator Light Combinations**

<b>OFF Mode</b>	Blender toggle switch is in the OFF position.
<b>Startup Mode</b>	Blender is in the process of starting the motor pump.
<b>Running Mode</b>	Blender is running the motor pump.
<b>Standby Mode</b>	There is not enough power from the solar PV panels for Blender to start the motor.
<b>Float Switch Mode</b>	Blender is turned OFF as a result of input from one or more external sensors that are connected to the digital input.
<b>Over Temperature Mode</b>	Blender stops operation when the temperature of the inside unit exceeds 80°C/176°F.
<b>Power Deration Mode</b>	Blender still operates but with reduced power throughput due to increased operating temperature, or if load is connected with current higher than <b>Over Current Protection</b> DIP Switches 6 and 7.
<b>Over Current Mode</b>	Blender stops operation when it detects high current on the motor terminals. This can also be due to a short circuit event if the unit is mis-wired. Requires manual restart by cycling power to the unit.
<b>Open Circuit Mode</b>	Blender will not start operation if the motor wiring does not align with DIP switch configuration.
<b>Dry Well Protection</b>	Blender detects dry well condition and ceases pump operation, which is restored after 30 minutes. If dry well indication appears faulty check that <b>Over Current Protection</b> <b>DIP Switches 6 and 7 are configured correctly.</b>

## Appendix A: How Blender 2500 Works

The Blender 2500 is a device that seamlessly blends energy between a solar array and the power grid. It is ideally suited for applications that require 24/7 or some night time operation, particularly in areas with high power costs.

This unique solution represents a cost-effective way to intelligently supplement solar power with controllable night time operation without the expense of adding a bank of batteries.

*Figure 28: How Blender 2500 Works*

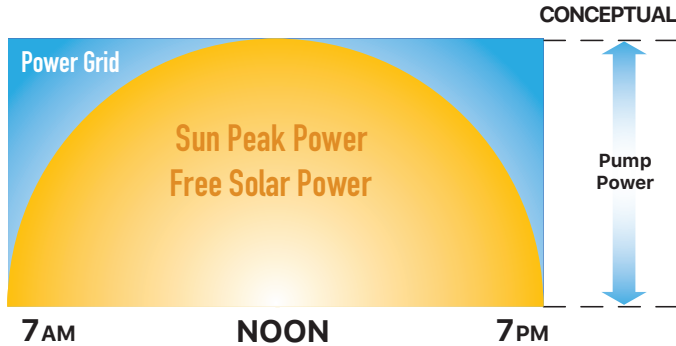

During times of full solar irradiance the Blender 2500 will draw all power from the PV array. When cloud cover or darkness reduces the level of solar irradiance the system will automatically draw power from the grid to make up the difference. As dusk approaches and turns to night the system will draw all of its power from the grid. This allows for both power firming during the day and full nighttime operation while consuming as little power from the grid as possible.

As shown in Figure 29: Sizing Solar PV Power With the Blender 2500 Controller, most of the daytime operation is effectively off-loaded from the grid. This is particularly useful in areas with high demand charges or time-of-use pricing. Typical applications include, but are not limited to, swimming pool pumps, decorative fountains, aerators and waste water treatment systems.

## Understand How to Maximize Solar Energy

Figure 29: Sizing Solar PV Power With the Blender 2500 Controller

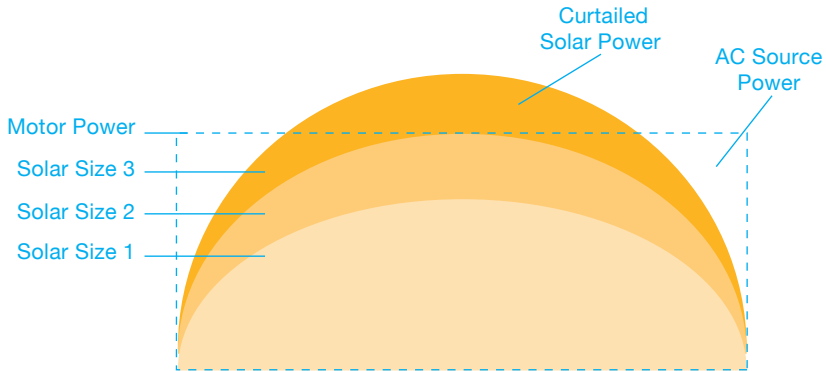

Figure 29: Sizing Solar PV Power With the Blender 2500 controller shows the principle of how utility energy can be offset using solar PV energy with the Blender 2500 controller.

- Motor power is shown by the dashed line.
- If the solar system is sized per Solar Size 1 then solar is offsetting just less than a half of total motor energy used during the day.
- In the case of Solar Size 2, where the solar PV system is sized to have the same capacity as the motor load, the motor will run completely off of solar during mid-day peak solar. During other periods of the day the Blender 2500 will blend power using both solar and AC power to provide the motor with the required power.
- In the case of Solar Size 3, where the solar PV system is sized with capacity higher than the motor load, the motor would run off of solar for longer periods during the day but during that time solar would also be curtailed as the motor power is less than solar capacity.

## Appendix B: Product Description, Product Specifications

### Blender 2500 Product Description

The Blender solar controller is a universal, high performance, variable speed motor controller for solar applications using single-phase and three-phase AC loads in a power range from 1/3 HP to 2 HP. The Blender offsets grid energy consumption by blending power between a solar PV array and an AC source.

The Blender controller is suitable for a variety of applications, including:

- *Livestock water supply*
- *Small scale irrigation*
- *Industrial farming ventilation*
- *Water transfer and evaporation*
- *Village water supply*
- *Aquaculture and aeration*
- *Swimming pool filtration*

The Blender can power new and previously installed (retrofit) AC motors. Please consult with a dealer to size the solar arrays when using the Blender.

For new installations, motor selection can also optimize the system economics. 230V three-phase motors are the most electrically efficient and require the least amount of solar, followed by 115V three-phase, 230V single-phase and 115V single-phase in descending order of efficiency.

NOTE: Motors controlled by the Blender do not require separate motor controls. The Blender was designed to be universal for most inductive motors while being mindful of some basic design limitations:

*The Blender may not operate 2-wire, single-phase motors that use switching devices to start. This includes, but is not limited to, 2-wire starting capacitors, both centrifugally switched and BIAC switched. Ask about ENFusion's Accessory Power Cable to retrofit 2-wire surface motors with starting caps.*

- The Blender can run motors with Service Factor Amps of 10 Amps or less for single-phase motors, and 8 Amps or less for three-phase motors.
- Generally, single-phase motors up to 1.5 HP will operate well.
- Generally, three-phase motors up to 2 HP will operate well.
- The Blender does not power Direct Current (DC) permanent magnet or Brushless DC (BLDC) motors.
- The Blender will replace the manufacturer's motor controller when installed on a Variable Speed Drive (VSD) or a Variable Frequency Drive (VFD) submersible pump motor.
- The Blender will replace the control box for 3-wire motors.
- The Blender will operate 2-wire motors with Permanent Split Capacitors (PSC).
- The Blender will not operate submersible motors with 2-wire starting capacitors, including Franklin Electric 2-wire submersibles and Grundfos 2-wire submersibles. ENFusion™ offers accessory cables to retrofit most 2-wire starting capacitor surface motors.

## Blender 2500 Specifications

### Input Specification:

- AC Grid Operating Voltage\*: **120V 60 Hz, single-phase**  
**240V 50/60 Hz, single-phase**
- Maximum AC input Current: **12A**
- Maximum Solar Open Circuit Voltage: **400V\*\***
- Maximum Solar PV Current in Series: **9A\*\*\***
- Earth-ground connected to chassis

\*Suitable For Use On A Circuit Capable of Delivering Not More Than 5000 rms Symmetrical Amperes, 230 Volts Maximum

\*\*DC PV input terminals shall only be connected to Listed Photovoltaic Modules and Panels that comply with UL 1703.

\*\*\*Suitable For Use On A Circuit Capable of Delivering Not More Than 13.5 rms Symmetrical Amperes, 400 Volts Maximum.

### Output Specification:

- Maximum Output Current: **10A (SINGLE-PHASE MOTORS)**
- Maximum Output Current: **8A (THREE-PHASE MOTORS)**
- Maximum Power Sustained: **2500W**

### Protections:

- Input AC Grid Overcurrent : 12A fused terminal block
- Short-circuit, ground-fault, over temperature, over-load, over voltage, over current, and solar input reverse polarity protection
- AC Load GFCI: 5, 10, or 30mA based on selected set-point (optional)
- Automatic dry well protection and pump locked rotor protection

Integral solid state short circuit protection does not provide branch circuit protection. Branch circuit protection must be provided in accordance with the National Electrical Code (NEC) and any additional local codes.

## Technical Specifications

### **ELECTRICAL**

AC input voltage range: **120-240V SINGLE-PHASE**

AC input maximum current: **12A**

Solar PV operating voltage range: **100-380V**

Solar PV rated current: **9A**

Certification: **UL 61800-5-1 STANDARD**

### **MECHANICAL**

Degree of protection: **NEMA3R/IP65**

Enclosure material: **CAST ALUMINUM**

Operating temperature: **-40°C TO 50°C**

Dimensions: **18" X 10" X 5"**

Solar terminal: **AWG#10-14**

Motor terminal: **AWG#10-14**

Sensor terminal passive: **AWG#14-22**

Cooling: **PASSIVE/NO FAN**



**Carefully check the motor load specifications, AC source voltage available and solar PV array maximum power point voltage to setup the system properly using this manual! If 120V is used as AC grid input, maximum load that can be connected is 1400W!**

## Appendix C: Calculate Maximum Cable Lengths for Different Motor Load Currents

Figure 30: Maximum Input Cable Lengths in Feet (Based on 3% Voltage Drop)

Motor LOAD [A]	Nominal Voltage [V]	AWG Copper Wire Sizes 90°C Insulation [ft]				
		16	14	12	10	8
4	115	110	165	270	400	600
	230	220	330	540	800	1200
6	115	70	110	175	275	400
	230	140	220	350	550	800
8	115	55	85	135	200	300
	230	110	170	270	400	600
10	115	45	70	105	165	240
	230	90	140	210	330	480
12	115	35	60	90	135	200
	230	70	120	180	270	400

**IMPORTANT: Use copper conductors only!**

This unit was evaluated for temperature rating of 60/75°C on power field wiring terminals.

## Appendix D: Optional Blender 2500 Module

### About the Cell\_GFCI (Ground Fault Circuit Interrupter) Module

Figure 31: Internal View of Blender 2500\_GFCI which is used for sensitive ground fault currents: 5, 10 and 30mA, which can be adjusted by using a simple jumper that is part of the GFCI module.

*Figure 31: Internal View of Blender 2500\_GFCI*

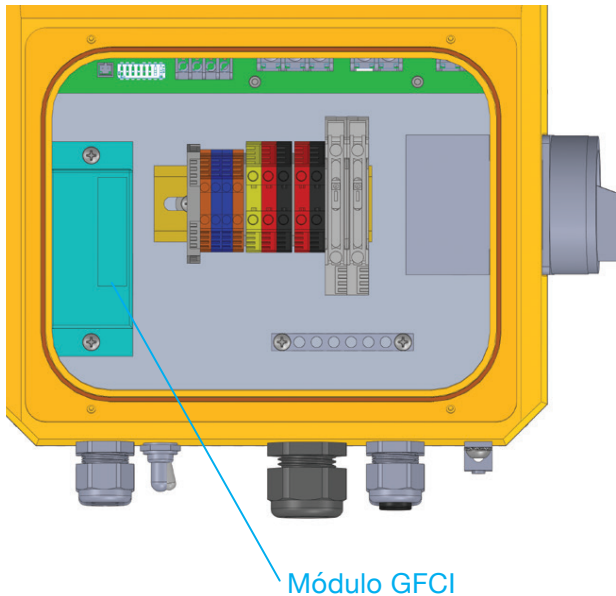

- The GFCI module is an integral part of the Blender 2500\_GFCI model and cannot be added in the field.
- A Blender 2500\_GFCI model must be ordered with this option and assembled at ENFusion's factory.
- The GFCI module is wired so that it instantaneously stops the Blender 2500 operation if the ground current is detected to be higher than the GFCI module settings (5, 10, or 30mA).
- The GFCI module is commonly used for aerators and fountains where the motor is submerged in open water such as lakes and ponds.

Ask your dealer about adding an optional GFCI module to your Blender 2500.

NOTES:

# Standard Terms and Conditions

## **enfusionenergy.com**

THIS DOCUMENT CONTAINS PREMIER ENERGY HOLDINGS, INC., AND ALL OF ITS SUBSIDIARIES (COLLECTIVELY REFERRED TO AS "PEH"), NORTH AMERICAN STANDARD LIMITED WARRANTY, GENERAL SALES POLICIES AND CONTROLLING TERMS AND CONDITIONS. THIS NORTH AMERICAN STANDARD LIMITED WARRANTY, GENERAL SALES POLICIES AND CONTROLLING TERMS AND CONDITIONS SHALL NOT BE ALTERED OR AMENDED EXCEPT PURSUANT TO AN AUTHORIZED PEH EXTENDED WARRANTY.

*PEH Standard Terms & Conditions are subject to change at any time.  
The latest version is available at ENFusionEnergy.com.*

### **EFFECTIVE DATE AND NO AGREEMENT OR AMENDMENTS**

This document and its provisions are effective as of February 1, 2022, and valid until further written notice from PEH. This document and its provisions shall supersede all pre-existing sales policies, terms and conditions, and standard limited warranties issued by PEH, whether in writing or orally. This document does not reflect an offer or an agreement to sell PEH products to any person or entity and should not be construed as such.

### **GENERAL SALES POLICIES AND CONTROLLING TERMS AND CONDITIONS**

PEH OBJECTS TO, AND SHALL NOT BE BOUND BY, ANY ADDITIONAL OR DIFFERENT TERMS OR CONDITIONS, WHETHER PRINTED OR OTHERWISE AND REGARDLESS OF WHETHER SUCH ADDITIONAL TERMS OR CONDITIONS ARE IN PURCHASER'S PURCHASE ORDER OR IN ANY OTHER COMMUNICATION FROM PURCHASER TO PEH.

The terms and conditions appearing in this agreement together with PEH's standard or custom product specifications (if applicable), constitute the entire agreement between PEH and Purchaser. PEH objects to, and shall not be bound by, any additional or different terms, whether printed or otherwise and whether in Purchaser's purchase order or in any other communication from Purchaser to PEH, unless PEH has specifically agreed in writing to those additional or different items. Prior courses of dealing, trade usage and verbal agreements not reduced to a writing signed by PEH to the extent they differ from, modify, add to, or detract from this agreement shall not be binding upon PEH. There are no other agreements, promises or understandings, either verbal or written, which are not fully expressed in this agreement. No statements, recommendations or assistance by either party have been relied upon by either party or shall constitute a waiver by either party of any of the provisions hereof. This agreement may be amended or altered only if agreed to in writing, signed by the party against which any such amendment or alteration is asserted.

- a. Acceptance and Payment PEH reserves the right to reject and refuse to process a purchase order for any reason whatsoever. If a Purchase Order (PO) or a line item contained in a PO is canceled by the Purchaser within five (5) days after PO acceptance by PEH, PEH reserves the right to apply cancellation charges of up to twenty percent (20%) of the invoice price of the canceled item(s).

The due date of payment shall be measured from the invoice date. Terms are net thirty (30) days from date of invoice of each shipment, unless otherwise stated.

Any portion of the purchase price which is not paid in accordance with applicable payment terms shall accrue interest at a rate equal to one and one-half percent (1 1/2 %) per month or the highest rate allowed by law, plus any attorney fees and other costs associated with collections. PEH shall apply payments received against outstanding invoices and/or interest charges at its discretion.

b. Prices and Taxes All prices and discounts are subject to change by PEH, with or without prior notice. Prices and discounts applicable to unshipped quantities of existing purchase orders, as well as to new purchase orders, shall be those in effect at the time of shipment. A representation by Purchaser of facts, upon which PEH relies in basing applicable discount or term of sale, shall be taken as a representation that such facts are true; and PEH shall have the right to revise any price or discount, including products already shipped, invoiced, or paid, should such representations be untrue. All prices are net of, and do not include, any federal, state, or local income, property, sales, use, excise, value-added, or other taxes, all of which shall be the responsibility of, and paid by, purchaser.

c. Quotations No price quotations for PEH products shall be binding on PEH unless confirmed in writing by PEH. Prices so quoted will be binding on PEH for thirty (30) days from the date of the price quotation unless noted in the quotation by PEH. Price quotations do not include accessories or components not manufactured by PEH. Clerical errors on any price quotations are subject to correction by PEH. Quotations are subject to change by PEH with notice to Purchaser.

d. Delivery Shipments may be made by common carrier, unless otherwise specified. Special arrangements, such as air freight, parcel shipment, overnight delivery and special packaging requirements must be specifically requested by Purchaser and, if agreed to in writing by PEH, will be at Purchaser's expense.

Any dates or schedules specified for the delivery of goods covered hereby are approximate only and are based upon then existing conditions and/or conditions reasonably anticipated through each shipping date. In addition to the limitation on damages described herein, PEH shall not, under any circumstances be liable for any loss, cost, expense, delay, damage, inconvenience, or consequential damages for failure (however caused) to meet a specific shipping date, or for any delay, loss, or damage in transit, or due to the unavailability of sufficient products to fill a purchase order. PEH reserves the right to allocate available inventories among its customers, including Purchaser, in the event that such inventories are inadequate to meet demand.

Title to the product shipped shall pass to Purchaser when PEH delivers such goods (i) to the carrier for delivery to Purchaser or (ii) to the dock for export shipments to Purchaser, and all risks of damage, loss, or delay shall thereupon pass to Purchaser. PEH shall promptly, after shipment, notify Purchaser that the goods have been delivered to the carrier or to the dock and shall furnish Purchaser with all documents, if any that are required to enable Purchaser to obtain possession of the product.

## **STANDARD LIMITED WARRANTY**

Except as set forth in an Extended Warranty, for two (2) years from the date of purchase, PEH hereby warrants to the purchaser ("Purchaser") of PE H's products that, for the applicable warranty period, the products purchased will (i) be free from defects in workmanship and material at the time of shipment, (ii) perform consistently with samples previously supplied and (iii) conform to the specifications published or agreed to in writing between the purchaser and PEH. This limited warranty extends only to products purchased directly from PEH. If a product is purchased other than from an authorized distributor, dealer or directly from PEH, such product must be installed by a PEH Certified Installer for this limited warranty to apply. This limited warranty is not assignable or transferable to any subsequent purchaser or user.

e. **THIS LIMITED WARRANTY IS IN LIEU OF ALL OTHER WARRANTIES, WRITTEN OR ORAL, STATUTORY, EXPRESS, OR IMPLIED, INCLUDING ANY WARRANTY OF MERCHANTABILITY OR FITNESS FOR A PARTICULAR PURPOSE. PURCHASER'S SOLE AND EXCLUSIVE REMEDY FOR PEH'S BREACH OF ITS OBLIGATIONS HEREUNDER, INCLUDING BREACH OF ANY EXPRESS OR IMPLIED WARRANTY OR OTHERWISE, UNLESS PROVIDED ON THE FACE HEREOF OR IN A WRITTEN INSTRUMENT MADE PART OF THIS LIMITED WARRANTY, SHALL BE FOR THE PURCHASE PRICE PAID TO PEH FOR THE NONCONFORMING OR DEFECTIVE PRODUCT OR FOR THE REPAIR OR REPLACEMENT OF NONCONFORMING OR DEFECTIVE PRODUCT, AT PEH'S ELECTION. ANY PEH PRODUCT WHICH PEH DETERMINES TO BE DEFECTIVE WITHIN THE WARRANTY PERIOD SHALL BE, AT PEH'S SOLE OPTION, REPAIRED, REPLACED WITH FACTORY REFURBISHED OR NEW PRODUCT WITH A MODEL OR VERSION NO OLDER THAN THAT OF ORIGINALLY PURCHASED PRODUCT, OR A REFUND OF THE PURCHASE PRICE PAID. REPAIR OR REPLACEMENT OF PRODUCT DOES NOT EXTEND THE ORIGINAL WARRANTY PERIOD.** Some states do not allow limitations on how long an implied warranty lasts, therefore, the limitations and exclusions relating to the products may not apply.

f. **WITHOUT LIMITING THE GENERALITY OF THE EXCLUSIONS OF THIS LIMITED WARRANTY, PEH SHALL NOT BE LIABLE TO THE PURCHASER OR ANY THIRD PARTY FOR ANY AND ALL (i) INCIDENTAL EXPENSES OR OTHER CHARGES, COSTS, EXPENSES (INCLUDING COSTS OF INSPECTION, TESTING, STORAGE, OR TRANSPORTATION) OR (ii) DAMAGES, INCLUDING CONSEQUENTIAL, SPECIAL DAMAGES, PUNITIVE OR INDIRECT DAMAGES, INCLUDING, WITHOUT LIMITATION, LOST PROFITS, LOST TIME AND LOST BUSINESS OPPORTUNITIES, REGARDLESS OF WHETHER PEH IS OR IS NOT SHOWN TO BE AT FAULT, AND REGARDLESS OF WHETHER THERE IS OR THERE IS NOT SHOWN TO HAVE BEEN A DEFECT IN MATERIALS OR WORKMANSHIP, NEGLIGENCE IN MANUFACTURE OR DESIGN, OR A FAILURE TO WARN.**

PEH's liability arising out of the sale or delivery of its products, or their use, whether based upon warranty contract, negligence, or otherwise, shall not in any case exceed the cost of repair or replacement of the product and, upon expiration of any applicable warranty period, any and all such liability shall terminate. Without limiting the generality of the exclusions of this limited warranty, PEH does not warrant the adequacy of any specifications provided directly or indirectly by a purchaser or that PEH's products will perform in accordance with such specifications.

This limited warranty does not apply to any products that have been subject to misuse (including use in a manner inconsistent with the design of the product), abuse, neglect, accident or improper installation or maintenance, or to products that have been altered or repaired by any person or entity other than PEH or its authorized representatives. Unless otherwise specified in an Extended Warranty authorized by PEH for a specific product or product line, this limited warranty does not apply to performance caused by abrasive materials, corrosion due to aggressive conditions or improper voltage supply.

With respect to PEH products, the following conditions automatically void this limited warranty:

1. Lightning damage (often referred to as high voltage surge damage).
2. Electrical failures due to the use of non-approved overload protection.
3. Unauthorized disassembly.

## **MISCELLANEOUS**

In compliance with Laws, Ordinances and Regulations PEH shall use reasonable efforts to cause the products to comply with federal safety, health and environmental regulations and insurance codes. However, PEH shall not be responsible for compliance of the products with local interpretations of such federal regulations or insurance codes, nor with any local laws, ordinances, codes and/or regulations which may at any time be in effect at any location where the products are to be used, unless such responsibility shall be expressly assumed by PEH in writing.

### *Change of Design*

PEH shall be entitled to make any and all changes in details of design, construction or arrangement of the product as PEH in its sole discretion determines will constitute an improvement upon the product or any specifications or designs previously furnished to the Purchaser.

### *PEH Remedies*

In addition to and notwithstanding any other remedy to which PEH may be entitled by law, in the event of Purchaser's breach of its obligations hereunder, or if Purchaser should cancel a purchase order, in whole or in part, or refuse to accept the products shipped hereunder, or wrongfully rejects or revokes its acceptance of products shipped that conform to a purchase order, Purchaser shall pay for, and PEH shall be entitled to recover from Purchaser, all special engineering, design, tooling, manufacturing, storage, or transportation costs incurred in connection with PEH's performance of the purchase order.

### *Infringement*

With respect to PEH's own standard designs and specifications, or specialty products which PEH has engineered and designed, PEH shall defend, indemnify and hold Purchaser harmless from and against any loss, damage, cost or expense arising out of any third-party claims for patent or trademark infringement relating to such products, so long as Purchaser promptly notifies PEH in writing of any such claim and gives PEH such authority, information and assistance as PEH may request in connection with the defense thereof.

Purchaser shall defend, indemnify and hold PEH harmless from and against any loss, damage, costs or expenses arising out of any claims of patent or trademark infringement relating to products manufactured by PEH in accordance with any designs or specifications furnished by Purchaser.

### *Special Tooling*

Any special tools, dies, jigs, molds, or other equipment manufactured or purchased by PEH, regardless of whether included as part of PEH's pricing, shall remain PEH's exclusive property.

### *Confidentiality*

All commercial, financial or technical information furnished by PEH shall be considered confidential and Purchaser shall not disclose any such information to any other person or use such information itself for any purpose other than the re-sale or the intended use of the products. This Section shall apply to drawings, specifications or

other documents prepared by us.

Unless otherwise agreed in writing, no information disclosed in any manner or at any time by Purchaser to PEH shall be deemed secret or confidential, and Purchaser shall have no rights against PEH with respect thereto, except such rights as may exist under applicable patent laws.

*Independent Contractors*

PEH and Purchaser are independent contractors and neither has the authority to assume or to create any obligation on behalf of or in the name of the other.

*Set Off*

PEH shall be entitled to set off any amount or apply any sum due from Purchaser to PEH or any other affiliated company of PEH.

*Force Majeure*

PEH shall not be responsible or liable for any delays or failures in manufacture or delivery due to any cause or condition beyond the reasonable control of PEH. PEH shall not be responsible or liable for any delays or failures to deliver or to perform its contractual responsibilities if due to causes beyond its reasonable control or the reasonable control of its suppliers, or due to acts of God, acts of civil or military authority, judicial action, fires, strikes, floods, wars, transportation delays, or inability due to causes beyond its reasonable control to obtain necessary labor, materials or manufacturing facilities. In the event of such a condition or circumstance, PEH shall have the right, at its option, to cancel any purchase orders or any part thereof without any resulting liability.

*Applicable Law*

The terms and conditions expressed herein shall be construed and its performance governed by the internal laws (as opposed to conflicts of law provisions) of the State of Colorado.

*Headings*

All headings or captions used herein are for convenience of reference only and shall not limit or define these terms and conditions.

*Interpretation*

Whenever the term "include", "includes", or "including" is used in this document or any document referenced in this document, it shall mean "including, without limitation," (whether or not such language is specifically set forth) and shall not be deemed to limit the range of possibilities to those items specifically enumerated. The words "hereof", "herein" and "hereunder" and words of similar import refer to this document and any document referenced in this document as a whole and not to any particular provision. Terms defined in the singular have a comparable meaning when used in the plural and vice versa.

## NOTES:



**info@enfusionenergy.com**

**(877) 230 7501**

**For further information scan this code:**



US Patents:

PATENT NO. 10,931,220

PATENT NO. 10,840,831

PATENT NO. 10,560,033

PATENT NO. 11,171,486

International Patents:

PATENT NO. (EP) 3,362,867

PATENT NO. (AU) 2016338999

PATENT NO. (CN) 108431719

**MADE IN THE  
USA**